

Cylinders

In the early 1950s, Clippard introduced miniature pneumatic cylinders and valves to the industry. No other manufacturer can match Clippard's level of experience or knowledge of miniature components. Need to replace a cylinder from another manufacturer? Clippard's online Interchange Guide makes it easy—simply search the other manufacturer's part number online at clippard.com and the Interchange will display the most similar Clippard cylinder, along with a full comparison of specifications.

Clippard manufactures a wide variety of special cylinders with custom stroke and rod modifications, special mounting configurations and ports, special seals and lubrication, unique integrated valving, and more. Call **877-245-6247** today to discuss how we can help you optimize your system with the perfect components for your application.



 **Interchange**
GUIDE

STAINLESS STEEL



- Over 130 different models
- 14 bore sizes
- Superior design and long life
- Thousands of items in stock for same-day shipping

pp. 136-147

ALL STAINLESS STEEL



- Durable 303 and 304 stainless steel
- 4 bore sizes
- FDA compliant grease lubrication
- Wipers standard

pp. 148-151

CORROSION-RESISTANT



- Durable 303 and 304 stainless steel
- FDA compliant grease lubrication
- Wipers standard
- 5 bore sizes

pp. 152-155

COMPACT EXTRUDED



- Interchangeable design allows for quick drop-in replacements
- 7 bore sizes
- Compact design for tight spaces

pp. 156-159

BRASS



- Original miniature cylinder line
- 4 bore sizes
- Robust, heavy-duty design
- Hydraulic or pneumatic

pp. 160-162

AIR VOLUME TANKS



- 10 standard models
- 1 to 16 cubic inches
- Custom sizes available
- Available in stainless, all stainless and polypropylene

p. 163

POSITION SENSORS p. 166

ACCESSORIES p. 164

Many items also available with metric ports.
For more information, visit clippard.com/link/metric

CYLINDERS

AVAILABLE OPTIONS

The following options are available for select Clippard cylinders.

Please note that not all options are available for all cylinders. Consult the charts (pp. 136-162) to see which options are available for a particular cylinder line or model.

CUSHIONS (C, F, R)

Provide adjustment to slow the cylinder near the end of the stroke, reducing impact and prolonging the life of the cylinder. Clippard cylinder cushions feature a captive adjustment that can be adjusted up to a dead stop 1/2" from the end of the stroke.

Read More: p. 134

MAGNETIC PISTON (M)

Equips the cylinder with an internal magnet, allowing it to be used with a reed switch or GMR sensor for accurate positioning.¹

Read More: p. 166

BUMPERS (B)

Reduce noise and shock to the load in applications where the cylinder is cycled with a light load and/or high speeds.¹

Max. Temperature: 200°F

WIPERS (W)

Added to cylinders to prevent contaminants from entering the cylinder assembly system.

Wipers are included standard on the All Stainless Steel line (no need to add a -W suffix to the part number).

FKM SEALS (V)

Used in applications which require special chemical compatibility or more extreme temperatures.

Temperature Range: -20 up to 400°F

ROD THREADS (N)

Various rod thread sizes are available, refer to cylinder charts for specifications. Rods are also available with no threads (N).

SIDE PORTED (S)

Side ported rear heads are sometimes needed when the standard cylinder has the rear port out the back. This option changes the design of the rear head so the rear port is located on the side of the cylinder.¹

HEAVY SPRING (H)

In single-acting, reverse-acting, or spring bias cylinders, this option provides a heavier spring to increase the standard spring force.

Standard and heavy spring forces are listed in Spring Forces Chart, p. 135

ROTATED PORTS (P2-8)

For applications where ports need to be rotated to accommodate specific space requirements or specific port orientation for fittings and tube attachments.

See diagram and chart (right)

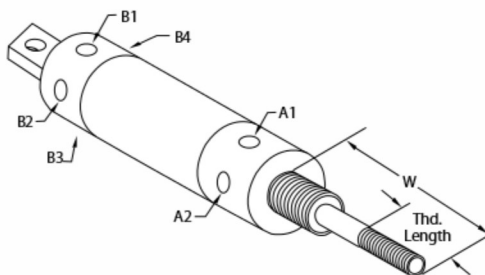

Option No.	Rear Port	Front Port
P2	B2	A2
P3	B1	A2
P4	B4	A2
P5	B3	A2
P6	B4	A1
P7	B3	A1
P8	B2	A1

PTFE GREASE (TG)

Seals lubricated with PTFE grease.

METRIC (M-prefix)

Compact Extruded line only.

LARGE ROD (LR)

Available on 1-1/4" bore round body line only.

ROD EXTENSIONS

If a special rod extension is required, refer to drawing above. For extensions on single- or double-acting cylinders, indicate desired "W" when rod is at rest with no pressure to either port. For reverse-acting, indicate "W" when rod is at rest with no pressure to either port.

¹Use of this option may add to the overall length of the cylinder.

CYLINDERS

CYLINDER & ROD TYPES

Cylinder Types

Single-Acting (S)

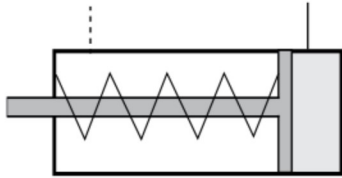

Single-acting cylinders provide power only on the extension ("push") stroke. A separate force—an internal spring—returns the piston to its original position for the next stroke.

Double-Acting (D)

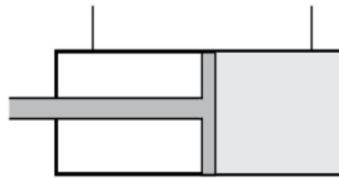

Double-acting cylinders have dual pressure chambers and provide pneumatic power on both extension ("push") and retraction ("pull"), eliminating the need for a spring.

Reverse-Acting (R)

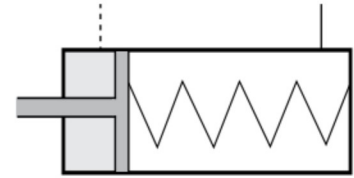

Reverse-acting cylinders are similar to single-acting but with a port on the opposite end to provide power only on the retraction ("pull") stroke.

Front Spring Bias (F)

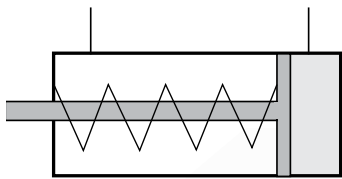

Front spring bias cylinders are double-acting cylinders with the addition of a spring on the front end. If all air is removed from the cylinder, the front spring bias cylinder will behave like a single-acting cylinder and shift to the retracted position.

Rear Spring Bias (B)

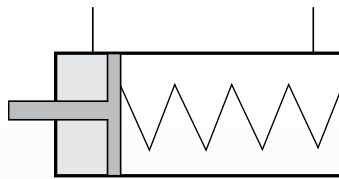

Rear spring bias cylinders are double-acting cylinders with the addition of a spring on the back end. If all air is removed from the cylinder, the rear spring bias cylinder will behave like a reverse-acting cylinder and shift to the extended position.

Rod Types

- **Double-Ended*** (D)
- **Rotating** (R)
- **Non-Rotating** (N)
- **Hollow** (H)

**Double-Acting cylinders only*

Need to replace a cylinder from another manufacturer?

Clippard's online **Interchange Guide** makes it easy to identify Clippard cylinders that are compatible with cylinders from other manufacturers. Just enter your cylinder part number into any search box on the clippard.com website to see a comparison.

clippard.com/link/interchange



CYLINDERS

CUSHIONS

Pneumatic cushions decelerate the piston and rod assembly at the end of the cylinders travel, reducing internal impact force/noise and enabling faster piston velocities. In fast cycling applications, cushioned cylinders will provide superior life and a better machine environment.

- Easily accessible, stainless steel needle for fine adjustment of cushion
- Long-lasting nitrile cushion seal
- Cushions the last 1/2" of stroke
- Available at front, rear, or both ends of cylinder
- Available with magnetic pistons

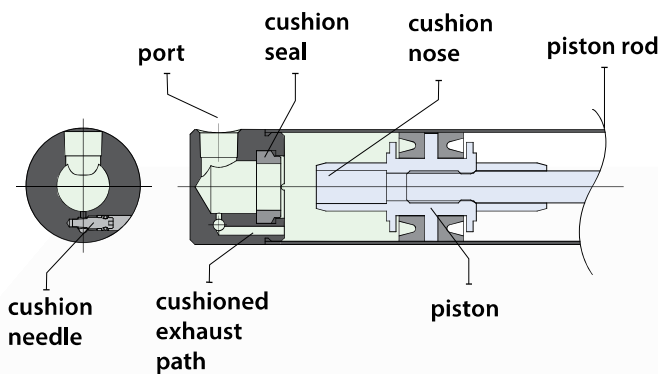

Cushions cannot be added to existing cylinders because this option requires additional components and machining. A cushion nose is located on either or both sides of the piston, depending on which cushion option is selected. The heads of a cushioned cylinder have a cushion pocket with a cushion seal. When the cushion nose enters the cushion seal, the air exiting the cylinder is trapped causing it to compress. This provides a resistance force that decelerates the piston.

In this design, a needle valve in the head provides a parallel path for the air to exit and is used to fine-tune the cushion's effectiveness. This needle design has a high flow gain which allows the user to tune the cushion anywhere from little effect to actually stopping the cylinder. The cushion seal collapses when air coming through the adjacent port is introduced, allowing for a fast breakaway.

CYLINDERS AVAILABLE WITH CUSHIONS

Bore Size	Part No.	Mounting	Both (C)	Front (F)	Rear (R)	Pg.
3/4"	SDD-12-	Stud	•	•		140
	SDH-12-	Stud	•	•	•	
	SDR-12-*	Stud	•	•	•	
	UDR-12-	Universal	•	•	•	
7/8"	SDD-14-	Stud	•	•		141
	SDH-14-	Stud	•	•		
	SDR-14-*	Stud	•	•	•	
	UDR-14-	Universal	•	•	•	
1-1/16"	SDD-17-	Stud	•	•		142
	SDH-17-	Stud	•	•	•	
	SDR-17-*	Stud	•	•	•	
	UDR-17-	Universal	•	•	•	
1-1/4"	SDD-20-	Stud	•	•		143
	SDR-20-*	Stud	•	•	•	
	UDR-20-	Universal	•	•	•	
1-1/2"	CDR-24-	Clevis	•	•	•	144
	EDR-24-	End Stud	•	•	•	
	SDD-24-	Stud	•	•		
	SDR-24-*	Stud	•	•	•	
1-3/4"	SDD-28-	Stud	•	•		145
	SDR-28-	Stud	•	•	•	
	UDR-28-	Universal	•	•	•	
2"	SDD-32-	Stud	•	•		146
	SDR-32-*	Stud	•	•	•	
	UDR-32-	Universal	•	•	•	
2-1/2"	SDD-40-	Stud	•	•		147
	SDR-40-*	Stud	•	•	•	
	UDR-40-	Universal	•	•	•	

1-1/16" and 1-1/2" bore cylinders with only one cushion include bumpers on the non-cushioned end

*SDR- models have side ported rear heads

Cushioned cylinders are not designed to decelerate machine members or take the place of shock absorbers in applications with high kinetic energy. Note also that bumpers cannot be used with cushions, but can be used opposite a cushion (as with the 1-1/16" and 1-1/2" bore cylinders).

CYLINDERS

FORCE FACTORS

The chart shown at right can be used to calculate cylinder force. The "force factors" listed indicate the nominal area for the bore and rod sizes shown. To calculate cylinder force, multiply the appropriate extend or retract force factor by the pressure being used. Clippard also recommends adding a 25% safety factor for normal load movement, or 40% for high speed applications.

FORCE FACTOR x **P** (Pressure) = **F** (Force)

F x **1.25** (25% Safety Factor) = **Normal Load Movement**

F x **1.40** (40% Safety Factor) = **High Speed Applications**

To calculate your own force factors:

A (Area) = **Radius**² x **π** (or **Diameter**² x 0.7854)

F = **P** x **A**

BORE SIZE	ROD SIZE	AREA OF ROD	EXTEND ¹	RETRACT ²
5/16"	1/8"	0.01 in ²	0.07 in ²	0.06 in ²
1/2"	3/16"	0.03 in ²	0.19 in ²	0.16 in ²
9/16"			0.25 in ²	0.22 in ²
5/8"			0.31 in ²	0.28 in ²
3/4"	1/4"	0.05 in ²	0.44 in ²	0.39 in ²
7/8"			0.60 in ²	0.55 in ²
1-1/16"	5/16"	0.08 in ²	0.88 in ²	0.80 in ²
1-1/4"	3/8"	0.11 in ²	1.20 in ²	1.09 in ²
1-1/2"	7/16"	0.15 in ²	1.70 in ²	1.55 in ²
1-3/4"	1/2"	0.20 in ²	2.40 in ²	2.20 in ²
2"	5/8"	0.31 in ²	3.10 in ²	2.90 in ²
2-1/2"			4.90 in ²	4.59 in ²
3"	3/4"	0.44 in ²	7.00 in ²	6.56 in ²

¹Area of bore; ²Area of bore minus area of rod

MAXIMUM LOAD BY ROD LENGTH

BORE SIZE	ROD SIZE	1"	5"	10"	15"	20"	25"	30"	35"	40"	
5/16"	1/8"	110 lbs.	12 lbs.	3 lbs.	1.3 lbs.						
1/2"	3/16"	262 lbs.	59 lbs.	15 lbs.	6.6 lbs.	3.7 lbs.					
9/16"											
5/8"											
3/4"	1/4"	478 lbs.	190 lbs.	47 lbs.	21 lbs.	12 lbs.	7.5 lbs.				
7/8"											
1-1/16"	5/16"	756 lbs.	451 lbs.	116 lbs.	52 lbs.	29 lbs.	19 lbs.	13 lbs.			
1-1/4"	3/8"	1,091 lbs.	786 lbs.	240 lbs.	106 lbs.	60 lbs.	38 lbs.	27 lbs.	20 lbs.		
1-1/2"	7/16"	1,490 lbs.	1,184 lbs.	444 lbs.	197 lbs.	111 lbs.	71 lbs.	49 lbs.	36 lbs.	28 lbs.	
1-3/4"	1/2"	1,950 lbs.	1,645 lbs.	757 lbs.	336 lbs.	189 lbs.	120 lbs.	84 lbs.	62 lbs.	47 lbs.	
2"	5/8"	3,055 lbs.	2,750 lbs.	1,795 lbs.	821 lbs.	462 lbs.	295 lbs.	205 lbs.	150 lbs.	115 lbs.	
2-1/2"											
3"	3/4"	4,405 lbs.	4,100 lbs.	3,140 lbs.	1,700 lbs.	950 lbs.	613 lbs.	425 lbs.	312 lbs.	240 lbs.	

SPRING FORCES

STANDARD	5/16"	1/2"	9/16"	5/8"	3/4"	7/8"	1-1/16"	1-1/4"	1-1/2"	1-3/4"	2"	2-1/2"
At Rest	0.5 lbs.	0.9 lbs.	1.7 lbs.	1.3 lbs.	3.0 lbs.	3.0 lbs.	2.0 lbs.	4.5 lbs.	4.5 lbs.	11.0 lbs.	15.0 lbs.	15.0 lbs.
Compressed	1.0 lbs.	2.0 lbs.	4.0 lbs.	4.0 lbs.	6.0 lbs.	6.0 lbs.	7.0 lbs.	10.0 lbs.	10.0 lbs.	24.0 lbs.	30.0 lbs.	30.0 lbs.
HEAVY												
At Rest	—	2.0 lbs.	—	3.3 lbs.	5.0 lbs.	5.0 lbs.	5.5 lbs.	8.5 lbs.	8.5 lbs.	—	—	—
Compressed	—	4.0 lbs.	—	9.0 lbs.	10.0 lbs.	10.0 lbs.	13.0 lbs.	17.0 lbs.	17.0 lbs.	—	—	—

Stainless Steel

Clippard's stainless steel air cylinders are manufactured to the highest standards of quality and reliability. Featuring a precision rolled body construction, this line is designed for long life, leak-free, low maintenance performance. In addition to quality and performance, Clippard's stainless steel cylinders provide superior design flexibility with a wide range of bore sizes from 5/16" up to 3" as well as a variety of mounting styles. Options available include magnetic pistons and rod wipers.

- High quality, precision rolled construction
- Low maintenance, durable design
- Low breakaway forces provide long life
- Wide variety of interchangeable mounting styles
- Over 130 different models
- Bore sizes from 5/16" up to 3"
- Magnetic pistons available
- Rod wipers available
- Thousands of versions in stock and available for same-day shipping

Bore Size	5/16" up to 3"
Cylinder Type	Single-Acting, Reverse-Acting, Double-Acting, or Spring Bias
Material, Bushing	Bronze
Material, End Caps	Aluminum
Material, Rod	304 Stainless steel
Material, Seal	Nitrile standard, FKM available
Material, Tube	303 Stainless steel
Mounting Style	Universal, stud, trunnion, front block, clevis, or end stud
Pressure, Max.	250 psig
Rod Type	Rotating, non-rotating, or double end
Temperature, Max.	230°F (400°F with FKM)
Temperature, Min.	32°F (-20°F with FKM)
More Info	clippard.com/link/cyl-ss

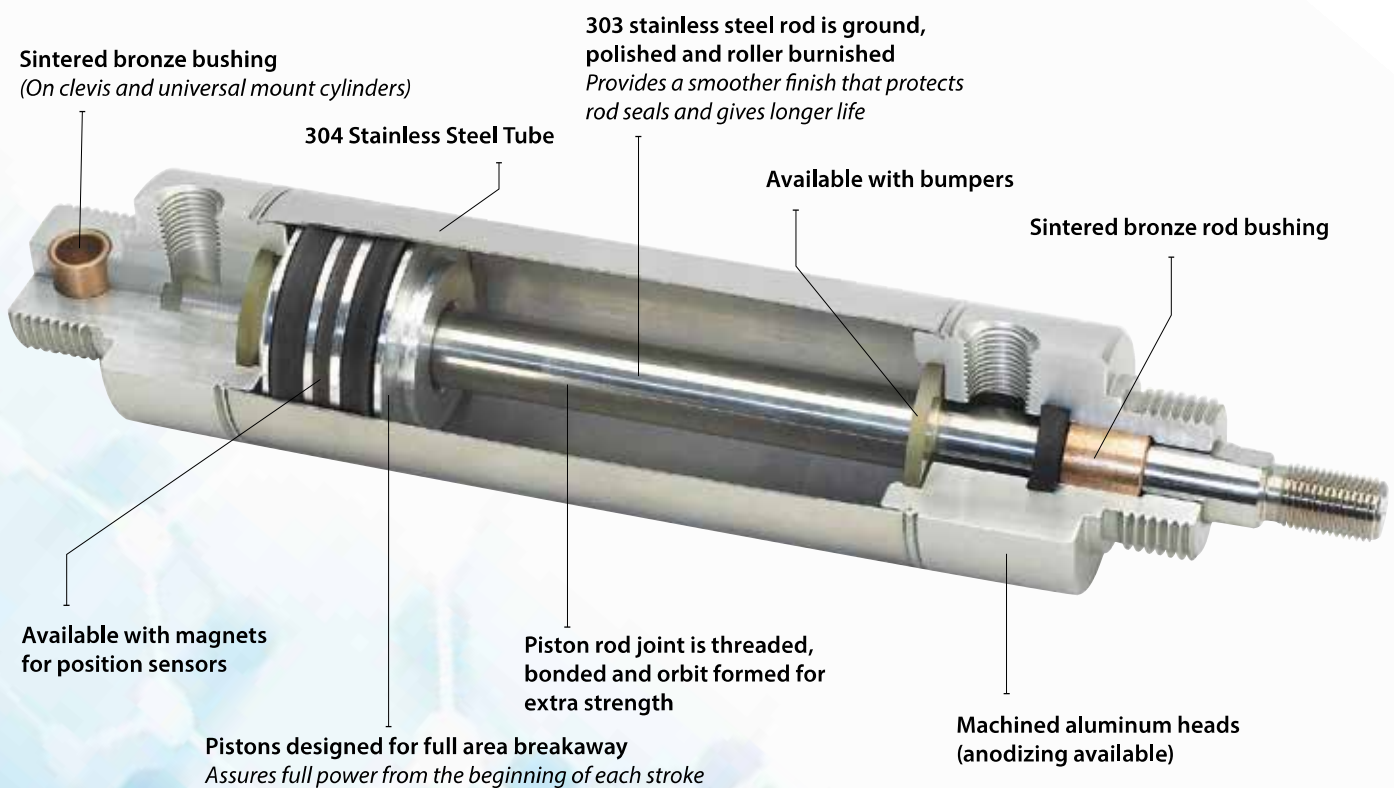

Mounting Styles

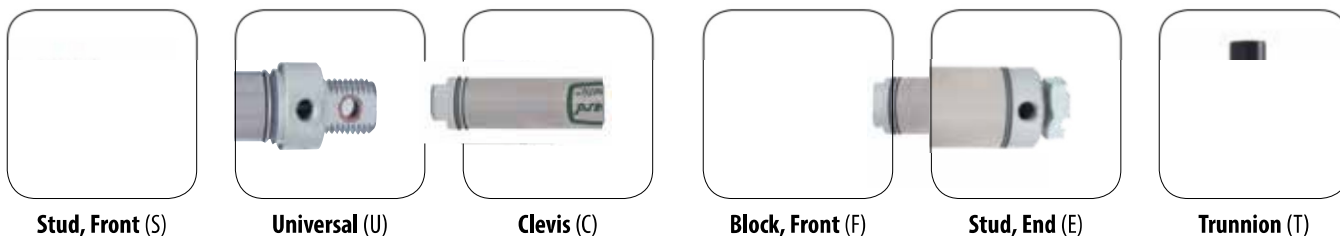

Stud, Front (S)

Universal (U)

Clevis (C)

Block, Front (F)

Stud, End (E)

Trunnion (T)

ORDERING INFORMATION

Please Note: Not all possible configurations shown below are available. Please reference the charts on the preceding pages for complete details or visit clippard.com/link/cyl-ss to use our online configurator.

After selecting a cylinder from one of the charts, simply add your **stroke** and **options** to the end of the **base part number** listed in the chart. This will provide the complete part number for your cylinder.

BASE PART NO.

-

-

-

Mounting Style

S	Stud, Front
U	Universal
C	Clevis
F	Block, Front
E	Stud, End
T	Trunnion

Mounting styles are pictured above

Rod Type

D	Double-Ended
N	Non-Rotating
R	Rotating
H	Hollow

Stroke

Inches and fractions of an inch (e.g. 1 or 1 1/2)

Refer to charts (pp. 138-147) for maximum stroke length

Options

C	Cushions
F	Cushion, Front
R	Cushion, Rear
M	Magnetic Piston
B	Bumpers
W	Rod Wiper
V	FKM Seals
N	No Threads
S	Side Ported
H	Heavy Spring
P	Rotated Ports
TG	PTFE-Based Grease
A	Anodized

Cylinder options are described in more detail on p. 132

Cylinder Type

S	Single-Acting
D	Double-Acting
R	Reverse-Acting
F	Front Spring Bias
B	Rear Spring Bias

Cylinder types are described in more detail on p. 133

Bore Size

05	5/16"
08	1/2"
09	9/16"
10	5/8"
12	3/4"
14	7/8"
17	1-1/16"
20	1-1/4"
24	1-1/2"
28	1-3/4"
32	2"
40	2-1/2"
48	3"

STAINLESS STEEL

5/16" & 1/2" BORE CYLINDERS

BORE SIZE

5/16"

Base Part No.	SSR-05-	USR-05-	SDR-05-	UDR-05-	SRR-05-	URR-05-
Cylinder Type	Single-Acting		Double-Acting		Reverse-Acting	
Mounting Style	Stud	Universal	Stud	Universal	Stud	Universal
Rod Type	Rotating	•	•	•	•	•
	Non-Rotating					
Maximum Stroke	29"	29"	43"	43"	17"	17"
Standard Rod Threads	#5-40					
Cushions (C, F, R)						
Magnetic Piston (M)						
Bumpers (B)	B	B	B	B	B	B
Options	Wipers (W)					
FKM Seals (V)	V	V	V	V	V	V
Side Ported (S)	S		S			
Heavy Spring (H)						
Other Rod Threads						
Threadless	N	N	N	N	N	N
Rotated Port Configurations <i>(See chart, p. 132)</i>		P6	P6, 7, 8	P2, 3, 4, 5, 6, 7, 8		P2, 3, 4, 5, 6, 7, 8

Part Numbering Schematic



BORE SIZE

1/2"

Base Part No.	FSR-08-	SSN-08-	SSR-08-	USN-08-	USR-08-	FDR-08-	SDR-08-	SDD-08-	UDR-08-	SRR-08-	URR-08-
Cylinder Type	Single-Acting					Double-Acting			Reverse-Acting		
Mounting Style	Front Block	Stud	Stud	Universal	Universal	Front Block	Stud	Stud	Universal	Stud	Universal
Rod Type	Rotating	•	•	•	•	•	•	Double End	•	•	•
	Non-Rotating		•	•							
Maximum Stroke	23"	23"	23"	23"	23"	43"	43"	20"	42"	15"	15"
Standard Rod Threads	#10-32										
Cushions (C, F, R)											
Magnetic Piston (M)	M	M	M	M	M	M	M	M	M	M	M
Bumpers (B)	B	B	B	B	B	B	B	B	B	B	B
Options	Wipers (W)		W		W	W	W	W	W	W	W
FKM Seals (V)	V	V	V	V	V	V	V	V	V	V	V
Side Ported (S)	S	S	S			S	S				
Heavy Spring (H)	H	H	H	H	H					H	H
Other Rod Threads	Specify option N1, N2, or N3: #10-24 (N1) • M5x0.8 (N2) • #8-32 (N3)										
Threadless	N	N	N	N	N	N	N	N	N	N	N
Rotated Port Configurations <i>(See chart, p. 132)</i>				P6	P6	P6, 7, 8	P6, 7, 8	P6, 7, 8	P2, 3, 4, 5, 6, 7, 8		P2, 3, 4, 5, 6, 7, 8

STAINLESS STEEL

9/16" BORE CYLINDERS

BORE SIZE

9/16"

Base Part No.	USN-09-	USR-09-	SSN-09-	SSR-09-	SDD-09-	SDR-09-	UDR-09-	SRR-09-	URR-09-
Cylinder Type	Single-Acting				Double-Acting			Reverse-Acting	
Mounting Style	Universal	Universal	Stud	Stud	Stud	Stud	Universal	Stud	Universal
Rod Type	Rotating	•	•	•	Double End	•	•	•	•
	Non-Rotating	•	•	•					
Maximum Stroke	23"	23"	23"	23"	20"	43"	43"	15"	14"
Standard Rod Threads	#10-32								
Options	Specify option N1, N2, or N3: #10-24 (N1) • M5x0.8 (N2) • #8-32 (N3)								
Cushions (C, F, R)									
Magnetic Piston (M)	M	M	M	M	M	M	M	M	M
Bumpers (B)	B	B	B	B	B	B	B	B	B
Wipers (W)									
FKM Seals (V)	V	V	V	V	V	V	V	V	V
Side Ported (S)									
Heavy Spring (H)									
Other Rod Threads	Specify option N1, N2, or N3: #10-24 (N1) • M5x0.8 (N2) • #8-32 (N3)								
Threadless	N	N	N	N	N	N	N	N	N
Rotated Port Configurations <i>(See chart, p. 132)</i>	P6	P6			P6, 7, 8	P6, 7, 8	P2, 3, 4, 5, 6, 7, 8		P2

CYLINDERS

Need to replace a cylinder from another manufacturer? No problem.

- 1 Enter your cylinder part number into any search box on the **clippard.com** website.
- 2 The cylinder will appear in your search results, next to the **Interchange Guide** logo.
- 3 The **Interchange Guide** will display compatible Clippard cylinders.

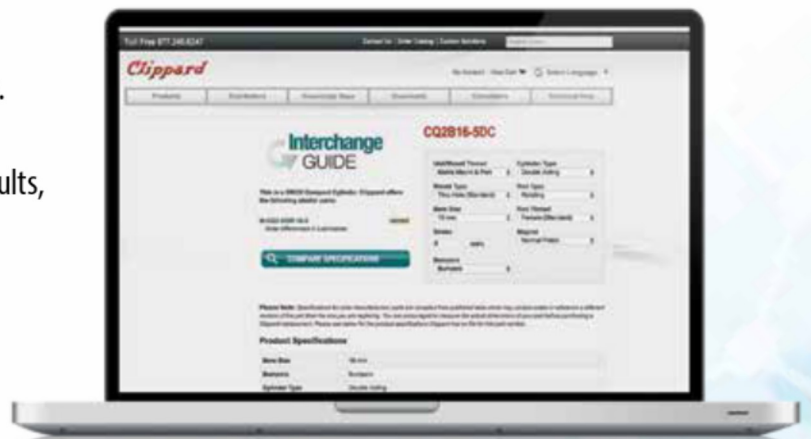

clippard.com/link/interchange

STAINLESS STEEL

5/8" & 3/4" BORE CYLINDERS

BORE SIZE

5/8"

Base Part No.	USN-10	USR-10-	SSN-10-	SSR-10-	FSR-10-	FDR-10-	SDR-10-	UDR-10-	SDD-10-	SRR-10-	URR-10-
Cylinder Type	Single-Acting					Double-Acting				Reverse-Acting	
Mounting Style	Universal	Universal	Stud	Stud	Front Block	Front Block	Stud	Universal	Stud	Stud	Universal
Rod Type	Rotating: • • • • • • • • • • • • Non-Rotating: • • • • • • • • • • • •										
Maximum Stroke	23"	23"	23"	23"	13"	43"	43"	43"	20"	15"	14"
Standard Rod Threads	#10-32										
Options	Cushions (C, F, R) Magnetic Piston (M) M M M M M M M M M M M M Bumpers (B) B B B B B B B B B B B B Wipers (W) W W W W W W W W W W W W FKM Seals (V) V V V V V V V V V V V V Side Ported (S) S S S S S S S S S S S S Heavy Spring (H) H H H H H H H H H H H H Other Rod Threads Specify option N1, N2, or N3: #10-24 (N1) • M5x0.8 (N2) • #8-32 (N3) Threadless N N N N N N N N N N N N										
Rotated Port Configurations <i>(See chart, p. 132)</i>	P6	P6				P6, 7, 8	P6, 7, 8	P2, 3, 4, 5, 6, 7, 8	P6, 7, 8		P2

Part Numbering Schematic



BORE SIZE

3/4" (Continued on next page)

Base Part No.	FSR-12-	SSN-12-	SSR-12-	TSR-12-	USN-12-	USR-12-	FDR-12-	TDR-12-	UDR-12-	SDR-12-	SDD-12-
Cylinder Type	Single-Acting						Double-Acting				
Mounting Style	Front Block	Stud	Stud	Trunnion	Universal	Universal	Front Block	Trunnion	Universal	Stud	Stud
Rod Type	Rotating: • • • • • • • • • • • • Non-Rotating: • • • • • • • • • • • •										
Maximum Stroke	25"	26"	26"	25"	25"	25"	42"	42"	41"	42"	20"
Standard Rod Threads	1/4-28										
Options	Cushions (C, F, R) C, F, R C, F, R C, F, R Magnetic Piston (M) M M M M M M M M M M M M Bumpers (B) B B B B B B B B B B B B Wipers (W) W W W W W W W W W W W W FKM Seals (V) V V V V V V V V V V V V Side Ported (S) S S S S S S S S S S S S Heavy Spring (H) H H H H H H H H H H H H Large Rod Other Rod Threads Specify option N1, N2, or N3: 1/4-20 (N1) • M6x1.0 (N2) • #10-32 (N3) Threadless N N N N N N N N N N N N										
Rotated Port Configurations <i>(See chart, p. 132)</i>					P6	P6	P6, 7, 8	P6, 7, 8	P2, 3, 4, 5, 6, 7, 8	P6, 7, 8	P6, 7, 8

STAINLESS STEEL

3/4" & 7/8" BORE CYLINDERS

BORE SIZE

3/4" (Continued from previous page)

Base Part No.	SDH-12-	SRR-12-	URR-12-	SFD-12-	SBR-12-	SFR-12-	UBR-12-	UFR-12-
Cylinder Type	Double-Acting	Reverse-Acting		Front Bias	Rear Bias	Front Bias	Rear Bias	Front Bias
Mounting Style	Stud	Stud	Universal	Stud	Stud	Stud	Universal	Universal
Rod Type	Rotating	Double (Hollow)	•	•	Double End	•	•	•
	Non-Rotating							
Maximum Stroke	20"	16"	15"	15"	15"	25"	15"	24"
Standard Rod Threads	1/4-28							
Cushions (C, F, R)	C, F							
Magnetic Piston (M)	M	M	M	M	M	M	M	M
Bumpers (B)	B	B	B	B	B	B	B	B
Options	Wipers (W)	W	W	W	W	W	W	W
	FKM Seals (V)	V	V	V	V	V	V	V
Side Ported (S)					S	S		
Heavy Spring (H)		H	H	H	H	H	H	H
Other Rod Threads	Specify option N1, N2, or N3: 1/4-20 (N1) • M6x1.0 (N2) • #10-32 (N3)							
Threadless	N	N	N	N	N	N	N	N
Rotated Port Configurations <i>(See chart, p. 132)</i>	P6, 7, 8		P2	P6, 7, 8	P6, 7, 8	P6, 7, 8	P2, 3, 4, 5, 6, 7, 8	P2, 3, 4, 5, 6, 7, 8

Part Numbering Schematic



Base Part No.

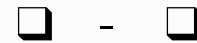

Stroke

Options

BORE SIZE

7/8"

Base Part No.	SSN-14-	SSR-14-	USN-14-	USR-14-	SDR-14-	SDD-14-	SDH-14-	UDR-14	SRR-14-	URR-14-
Cylinder Type	Single-Acting				Double-Acting			Reverse-Acting		
Mounting Style	Stud		Universal		Stud		Universal	Stud	Universal	
Rod Type	Rotating	•	•	•	•	Double End	Double (Hollow)	•	•	•
	Non-Rotating	•	•							
Maximum Stroke	27"	27"	27"	27"	42"	20"	20"	41"	16"	16"
Standard Rod Threads	1/4-28									
Cushions (C, F, R)					C, F, R	C, F	C, F	C, F, R		
Magnetic Piston (M)	M	M	M	M	M	M	M	M	M	M
Bumpers (B)	Standard									
Options	Wipers (W)	W	W	W	W	W	W	W	W	W
	FKM Seals (V)	V	V	V	V	V	V	V	V	V
Side Ported (S)	S	S			S					
Heavy Spring (H)	H	H	H	H					H	H
Large Rod										
Other Rod Threads	Specify option N1, N2, or N3: 1/4-20 (N1) • M6x1.0 (N2) • #10-32 (N3)									
Threadless	N	N	N	N	N	N	N	N	N	N
Rotated Port Configurations <i>(See chart, p. 132)</i>			P6	P6	P6, 7, 8	P6, 7, 8	P6, 7, 8	P2, 3, 4, 5, 6, 7, 8		P2

STAINLESS STEEL

1-1/16" BORE CYLINDERS

BORE SIZE

1-1/16"

Base Part No.	SSN-17-	SSR-17-	USN-17-	USR-17-	FSR-17-	TSR-17-	SDR-17-	SDD-17-	SDH-17-	UDR-17-	FDR-17-
Cylinder Type	Single-Acting						Double-Acting				
Mounting Style	Stud		Universal		Front Block	Trunnion	Stud			Universal	Front Block
Rod Type	Rotating		•		•	•	•	Double End	Double (Hollow)	•	•
	Non-Rotating		•		•	•	•	•	•	•	•
Maximum Stroke	27"	27"	27"	27"	27"	26"	42"	20"	20"	41"	42"
Standard Rod Threads	5/16-24										
Options	Cushions (C, F, R)						C, F, R	C, F, R	C, F, R	C, F, R	
	Magnetic Piston (M)	M	M	M	M	M	M	M	M	M	M
	Bumpers (B)	B	B	B	B	B	B	B	B	B	B
	Wipers (W)		W		W	W	W	W	W	W	W
	FKM Seals (V)	V	V	V	V	V	V	V	V	V	V
	Side Ported (S)	S	S			S	S	S			S
	Heavy Spring (H)	H	H	H	H	H					
	Large Rod										
	Other Rod Threads	Specify option N1, N2, or N3: 5/16-18 (N1) • M8x1.25 (N2) • 1/4-28 (N3)									
	Threadless	N	N	N	N	N	N	N	N	N	N
Rotated Port Configurations <i>(See chart, p. 132)</i>			P6	P6			P6, 7, 8	P6, 7, 8	P6, 7, 8	P2, 3, 4, 5, 6, 7, 8	P6, 7, 8

Part Numbering Schematic



Base Part No.



Stroke

Options

BORE SIZE

1-1/16"

Base Part No.	TDR-17-	SRR-17-	URR-17-	SFD-17-	SFR-17-	UFR-17-	SBR-17-	UBR-17-
Cylinder Type	Double-Acting	Reverse-Acting		Front Bias			Rear Bias	
Mounting Style	Trunnion	Stud	Universal	Stud		Universal	Stud	Universal
Rod Type	Rotating		•		Double End	•	•	•
	Non-Rotating		•		•	•	•	•
Maximum Stroke	42"	16"	16"	15"	26"	26"	16"	16"
Standard Rod Threads	5/16-24							
Options	Cushions (C, F, R)							
	Magnetic Piston (M)	M	M	M	M	M	M	M
	Bumpers (B)	B	B	B	B	B	B	B
	Wipers (W)	W	W	W	W	W	W	W
	FKM Seals (V)	V	V	V	V	V	V	V
	Side Ported (S)	S			S		S	
	Heavy Spring (H)		H	H	H	H	H	H
	Large Rod							
	Other Rod Threads	Specify option N1, N2, or N3: 5/16-18 (N1) • M8x1.25 (N2) • 1/4-28 (N3)						
	Threadless	N	N	N	N	N	N	N
Rotated Port Configurations <i>(See chart, p. 132)</i>	P6, 7, 8		P2	P6, 7, 8	P6, 7, 8	P2, 3, 4, 5, 6, 7, 8	P6, 7, 8	P2, 3, 4, 5, 6, 7, 8

STAINLESS STEEL

1-1/4" BORE CYLINDERS

BORE SIZE

1-1/4"

Base Part No.	SSN-20-	SSR-20-	USN-20-	USR-20-	SDD-20-	SDR-20-	UDR-20-	SRR-20-	URR-20-	SFR-20	UFR-20	SBR-20	UBR-20
Cylinder Type	Single-Acting				Double-Acting			Reverse-Acting		Front Bias		Rear Bias	
Mounting Style	Stud		Universal		Stud		Universal	Stud	Universal	Stud	Universal	Stud	Universal
Rod Type	Rotating	•	•	•	Double End	•	•	•	•	•	•	•	•
	Non-Rotating	•	•	•									
Maximum Stroke	23"	23"	22"	22"	19"	41"	40"	14"	14"	22"	21"	16"	15"
Standard Rod Threads	3/8-24												
Options	Cushions (C, F, R)				C, F	C, F, R	C, F, R						
Magnetic Piston (M)	M	M	M	M	M	M	M	M	M	M	M	M	M
Bumpers (B)	B	B	B	B	B	B	B	B	B	B	B	B	B
Wipers (W)					W	W	W	W	W	W	W		
FKM Seals (V)	V	V	V	V	V	V	V	V	V	V	V	V	V
Side Ported (S)	S	S				S				S			
Heavy Spring (H)	H	H	H	H				H	H	H	H	H	H
Large Rod (LR)	LR	LR	LR	LR	LR	LR	LR	LR	LR				
Other Rod Threads	Specify option N1, N2, or N3: 3/8-16 (N1) • M8x1.25 (N2) • 5/16-24 (N3)												
Threadless	N	N	N	N	N	N	N	N	N	N	N	N	N
Rotated Port Configurations (See chart, p. 132)			P6	P6	P6, 7, 8	P6, 7, 8	P2, 3, 4, 5, 6, 7, 8		P2				

CYLINDERS

Need to replace a cylinder from another manufacturer? No problem.

- 1 Enter your cylinder part number into any search box on the **clippard.com** website.
- 2 The cylinder will appear in your search results, next to the **Interchange Guide** logo.
- 3 The **Interchange Guide** will display compatible Clippard cylinders.



clippard.com/link/interchange

STAINLESS STEEL

1-1/2" BORE CYLINDERS

BORE SIZE

1-1/2"

Base Part No.	CSN-24-	CSR-24-	ESN-24-	ESR-24-	FSR-24-	SSN-24-	SSR-24-	TSR-24-	CDR-24-	
Cylinder Type	Single-Acting								Double-Acting	
Mounting Style	Clevis	Clevis	End Stud	End Stud	Front Block	Stud	Stud	Trunnion	Clevis	
Rod Type	Rotating	•		•	•		•	•	•	
	Non-Rotating	•		•		•				
Maximum Stroke	24"	24"	24"	15"	24"	24"	24"	23"	39"	
Standard Rod Threads	7/16-20									
Options	Cushions (C, F, R)								C, F, R	
	Magnetic Piston (M)	M	M	M	M	M	M	M	M	
	Bumpers (B)	M	B	B	B	B	B	B	B	
	Wipers (W)		W		W	W		W	W	
	FKM Seals (V)	V	V	V	V	V	V	V	V	
	Side Ported (S)					S	S	S	S	
	Heavy Spring (H)	H	H	H	H	H	H	H	H	
	Other Rod Threads	Specify option N1, N2, or N3: 7/16-14 (N1) • M10x1.5 (N2) • 3/8-24 (N3)								
	Threadless	N	N	N	N	N	N	N	N	N
Rotated Port Configurations <i>(See chart, p. 132)</i>	P6	P6							P2, 3, 4, 5, 6, 7, 8	

Part Numbering Schematic



BORE SIZE

1-1/2" (Continued on next page)

Base Part No.	EDR-24-	FDR-24-	SDR-24-	TDR-24-	SDD-24-	CRR-24-	ERR-24-	FRR-24-	
Cylinder Type	Double-Acting					Reverse-Acting			
Mounting Style	End Stud	Front Block	Stud	Trunnion	Stud	Clevis	End Stud	Front Block	
Rod Type	Rotating	•	•	•	•	Double End	•	•	•
	Non-Rotating								
Maximum Stroke	39"	40"	40"	40"	19"	14"	14"	15"	
Standard Rod Threads	7/16-20								
Options	Cushions (C, F, R)	C, F, R		C, F, R		C, F			
	Magnetic Piston (M)	M	M	M	M	M	M	M	
	Bumpers (B)	B	B	B	B	B	B	B	
	Wipers (W)	W	W	W	W	W	W	W	
	FKM Seals (V)	V	V	V	V	V	V	V	
	Side Ported (S)		S	S					
	Heavy Spring (H)						H	H	H
	Other Rod Threads	Specify option N1, N2, or N3: 7/16-14 (N1) • M10x1.5 (N2) • 3/8-24 (N3)							
	Threadless	N	N	N	N	N	N	N	N
Rotated Port Configurations <i>(See chart, p. 132)</i>	P6, 7, 8	P6, 7, 8	P6, 7, 8	P6, 7, 8	P6, 7, 8	P2, 3, 4, 5, 6, 7, 8			

STAINLESS STEEL

1-1/2" & 1-3/4" BORE CYLINDERS

BORE SIZE

1-1/2" (Continued from previous page)

Base Part No.	SRR-24-	CBR-24-	CFR-24-	EBR-24-	EFR-24-	SFD-24-	SBR-24-	SFR-24-	
Cylinder Type	Reverse-Acting	Rear Bias	Front Bias	Rear Bias	Front Bias	Front Bias	Rear Bias	Front Bias	
Mounting Style	Stud	Clevis	Clevis	End Stud	End Stud	Stud	Stud	Stud	
Rod Type	Rotating	•	•	•	•	•	Double End	•	
	Non-Rotating								
Maximum Stroke	15"	14"	23"	14"	23"	14"	15"	23"	
Standard Rod Threads	7/16-20								
Options	Cushions (C,F,R)								
	Magnetic Piston (M)	M	M	M	M	M	M	M	
	Bumpers (B)	B	B	B	B	B	B	B	
	Wipers (W)	W	W	W	W	W	W	W	
	FKM Seals (V)	V	V	V	V	V	V	V	
	Side Ported (S)						S	S	
	Heavy Spring (H)	H	H	H	H	H	H	H	
	Other Rod Threads	Specify option N1, N2, or N3: 7/16-14 (N1) • M10x1.5 (N2) • 3/8-24 (N3)							
	Threadless	N	N	N	N	N	N	N	
Rotated Port Configurations (See chart, p. 132)		P2, 3, 4, 5, 6, 7, 8	P2, 3, 4, 5, 6, 7, 8	P6, 7, 8	P6, 7, 8	P6, 7, 8	P6, 7, 8	P6, 7, 8	

Part Numbering Schematic



BORE SIZE

1-3/4"

Base Part No.	SSN-28-	SSR-28-	USN-28-	USR-28-	SDR-28-	UDR-28-	SDD-28-	SRR-28-	URR-28-	
Cylinder Type	Single-Acting				Double-Acting			Reverse-Acting		
Mounting Style	Stud	Stud	Universal	Universal	Stud	Universal	Stud	Stud	Universal	
Rod Type	Rotating	•	•	•	•	•	Double End	•	•	
	Non-Rotating	•	•	•	•	•				
Maximum Stroke	20"	20"	19"	19"	39"	37"	18"	13"	12"	
Standard Rod Threads	1/2-20									
Options	Cushions (C,F,R)				C,F,R	C,F,R	C,F			
	Magnetic Piston (M)	M	M	M	M	M	M	M	M	
	Bumpers (B)	Standard								
	Wipers (W)		W		W	W	W	W	W	
	FKM Seals (V)	V	V	V	V	V	V	V	V	
	Side Ported (S)	S	S		S					
	Heavy Spring (H)									
	Other Rod Threads	Specify option N1, N2, or N3: 1/2-13 (N1) • M12x1.5 (N2) • 7/16-20 (N3)								
	Threadless	N	N	N	N	N	N	N	N	
Rotated Port Configurations (See chart, p. 132)			P6	P6	P6, 7, 8	P2, 3, 4, 5, 6, 7, 8	P6, 7, 8		P2	

STAINLESS STEEL

2" BORE CYLINDERS

BORE SIZE

2"

Base Part No.	SSR-32-	USR-32-	SDR-32-	UDR-32-	SDD-32-
Cylinder Type	Single-Acting		Double-Acting		
Mounting Style	Stud	Universal	Stud	Universal	Stud
Rod Type	Rotating •	•	•	•	Double End
	Non-Rotating				
Maximum Stroke	20"	19"	39"	38"	18"
Standard Rod Threads	1/2-20				
Cushions (C, F, R)			C, F, R	C, F, R	C, F
Options Magnetic Piston (M)	M	M	M	M	M
Bumpers (B)	B	B	B	B	B
Wipers (W)	W	W	W	W	W
FKM Seals (V)	V	V	V	V	V
Side Ported (S)	S		S		
Heavy Spring (H)					
Other Rod Threads	Specify option N1, N2, or N3: 1/2-13 (N1) • M12x1.5 (N2) • 7/16-20 (N3) • 5/8-18 (N4)				
Threadless	N	N	N	N	N
Rotated Port Configurations <i>(See chart, p. 132)</i>		P6	P6, 7, 8	P2, 3, 4, 5, 6, 7, 8	P6, 7, 8

Part Numbering Schematic



BORE SIZE

2"

Base Part No.	SRR-32-	URR-32-	SFR-32-	SBR-32-	UFR-32-	UBR-32-
Cylinder Type	Reverse-Acting		Front Bias	Rear Bias	Front Bias	Rear Bias
Mounting Style	Stud	Universal	Stud	Stud	Universal	Universal
Rod Type	Rotating •	•	•	•	•	•
	Non-Rotating					
Maximum Stroke	12"	13"	19"	13"	18"	12"
Standard Rod Threads	1/2-20					
Cushions (C, F, R)						
Options Magnetic Piston (M)	M	M	M	M	M	M
Bumpers (B)	B	B	B	B	B	B
Wipers (W)	W	W	W	W	W	W
FKM Seals (V)	V	V	V	V	V	V
Side Ported (S)			S	S		
Heavy Spring (H)						
Other Rod Threads	Specify option N1, N2, or N3: 1/2-13 (N1) • M12x1.5 (N2) • 7/16-20 (N3) • 5/8-18 (N4)					
Threadless	N	N	N	N	N	N
Rotated Port Configurations <i>(See chart, p. 132)</i>		P2	P6, 7, 8	P6, 7, 8	P2, 3, 4, 5, 6, 7, 8	P2, 3, 4, 5, 6, 7, 8

STAINLESS STEEL

2-1/2" & 3" BORE CYLINDERS

BORE SIZE

2-1/2"

3"

Base Part No.	SDR-40-	UDR-40-	SDD-40-	SDR-48-	UDR-48-	SDD-48-
Cylinder Type	Double-Acting			Double-Acting		
Mounting Style	Stud	Universal	Stud	Stud	Universal	Stud
Rod Type	Rotating	•	•	Double End	•	•
	Non-Rotating					Double End
Maximum Stroke	39"	38"	18"	34"	32"	15"
Standard Rod Threads	1/2-20			5/8-18		
Cushions (C, F, R)	C, F, R	C, F, R	C, F			
Magnetic Piston (M)	M	M	M	M	M	M
Bumpers (B)	Standard			Standard		
Wipers (W)	W	W	W	W	W	W
FKM Seals (V)	V	V	V	V	V	V
Side Ported (S)	S			S		
Other Rod Threads	Specify option N1, N2, or N3: 1/2-13 (N1) • M12x1.5 (N2) • 7/16-20 (N3) • 5/8-18 (N4)			Specify option N1, N2, or N3: 5/8-11 (N1) • M16x1.5 (N2) • 1/2-20 (N3) • 3/4-16 (N4)		
Threadless	N	N	N	N	N	N
Rotated Port Configurations <i>(See chart, p. 132)</i>	P6, 7, 8	P2, 3, 4, 5, 6, 7, 8	P6, 7, 8	P6, 7, 8	P2, 3, 4, 5, 6, 7, 8	P6, 7, 8

Part Numbering Schematic



Need to replace a cylinder from another manufacturer? No problem.

- 1 Enter your cylinder part number into any search box on the **clippard.com** website.
- 2 The cylinder will appear in your search results, next to the **Interchange Guide** logo.
- 3 The **Interchange Guide** will display compatible Clippard cylinders.

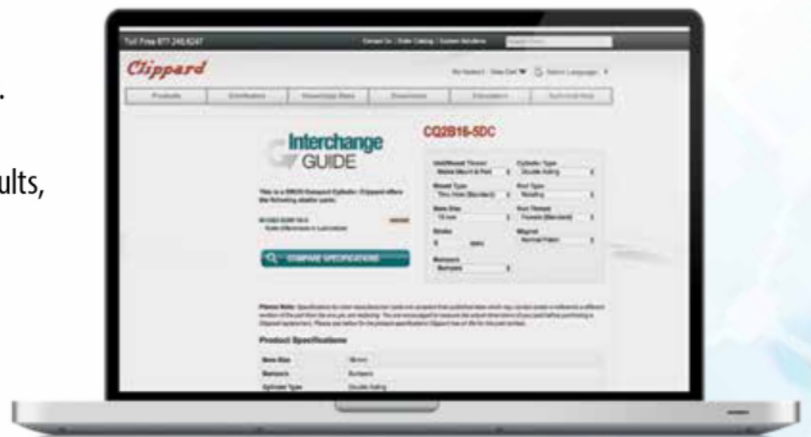

clippard.com/link/interchange

All Stainless Steel

Designed for use in a broad range of applications including those in washdown and caustic environments, these high quality cylinders are constructed of durable 303 and 304 stainless steel. They include a nitrile rod wiper to keep potential contaminants from penetrating inside the cylinder, and are available in bore sizes from 3/4" to 2". Standard stroke lengths are from 1" up to 32" on some models.

- Ideal for harsh, caustic environments
- High quality, precision rolled construction
- Constructed of durable 303 & 304 stainless steel
- Low maintenance, durable design
- Low breakaway forces provide long life
- Wide variety of interchangeable mounting styles
- Bore sizes from 3/4" up to 2"
- Nitrile rod wipers
- FDA compliant grease
- Magnetic pistons available

Bore Size	3/4" up to 2"
Cylinder Type	Double-Acting
Lubrication	FDA compliant grease standard, Magnalube® available
Material, Bushing	FDA compliant Rulon®
Material, End Caps	303 Stainless steel
Material, Rod	303 Stainless steel
Material, Seal	Nitrile standard, FKM available
Material, Tube	304 Stainless steel
Mounting Style	Stud, universal, clevis, or end
Pressure, Max.	250 psig
Rod Type	Rotating or double end
Rod Wipers	Included (nitrile)
Temperature	-20 to 230°F (-20 to 400°F with FKM)
More Info	clippard.com/link/cyl-allss

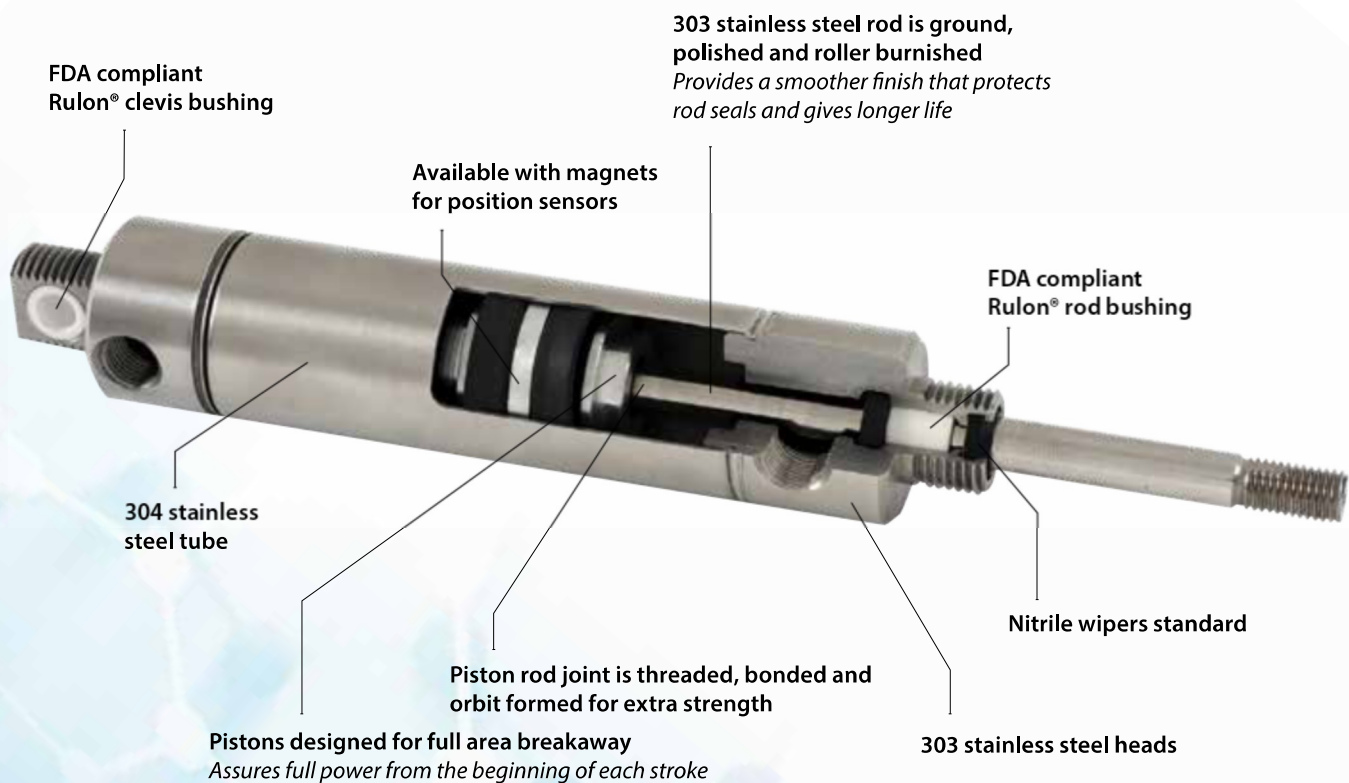

303 stainless steel rod is ground, polished and roller burnished
Provides a smoother finish that protects rod seals and gives longer life

Mounting Options

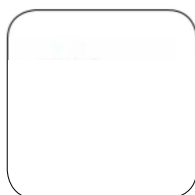

Stud, Front (S)



Universal (U)



Clevis (C)



Stud, End (E)

ORDERING INFORMATION

Please Note: Not all possible configurations shown below are available. Please reference the charts on the preceding pages for complete details or visit clippard.com/link/cyl-allss to use our online configurator.

After selecting a cylinder from one of the charts, simply add your **stroke** and **options** to the end of the **base part number** listed in the chart. This will provide the complete part number for your cylinder.

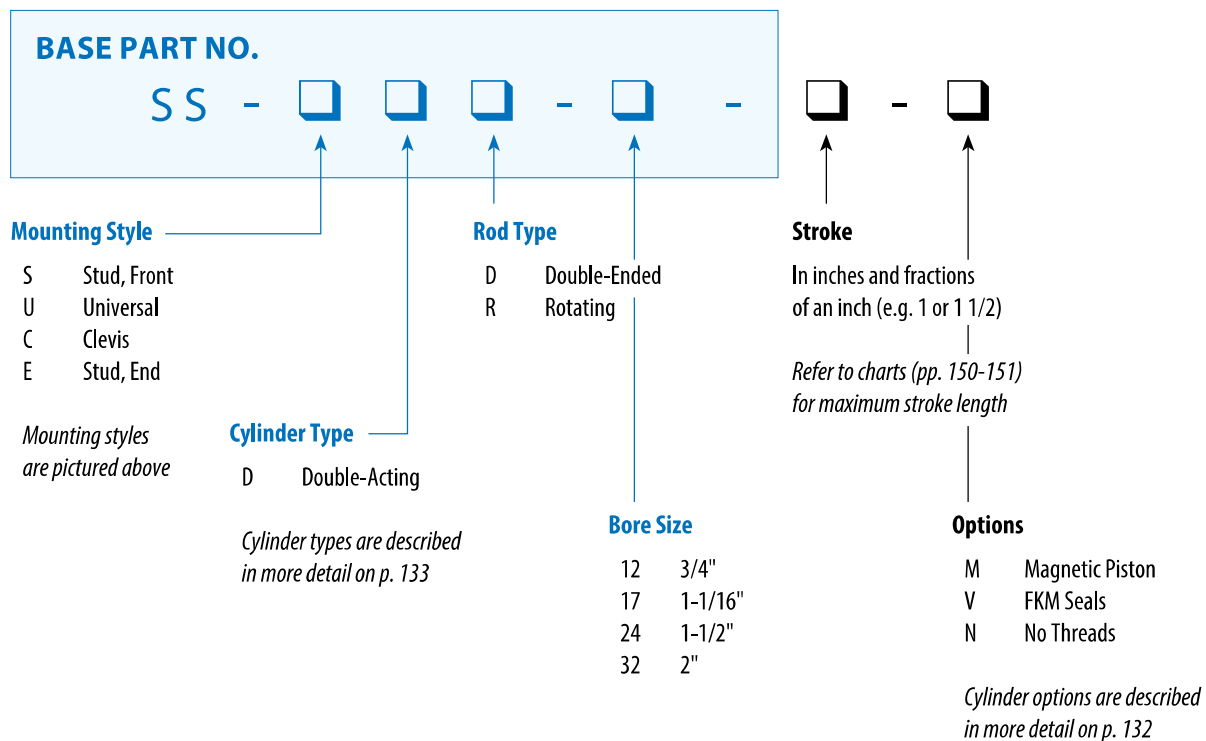

ALL STAINLESS

3/4", 1-1/16", 1-1/2" & 2" BORE CYLINDERS

BORE SIZE

3/4"

1-1/16"

Base Part No.	SS-SDR-12-	SS-UDR-12-	SS-UDD-12-	SS-SDR-17-	SS-UDR-17-	SS-SDD-17-	
Cylinder Type	Double-Acting			Double-Acting			
Mounting Style	Stud	Universal	Universal	Stud	Universal	Stud	
Rod Type	Rotating	•	•	Double End	•	•	Double End
	Non-Rotating						
Maximum Stroke	12"	32"	6"	12"	24"	6"	
Standard Rod Threads	1/4-28			5/16-24			
Options							
Cushions (C, F, R)							
Magnetic Piston (M)	M	M	M	M	M	M	
Bumpers (B)							
Wipers (W)							
FKM Seals (V)	V	V	V	V	V	V	
PTFE Grease (TG)	TG	TG	TG	TG	TG	TG	
Other Rod Threads (N1, N2, N3)	1/4-20 (N1) M6x1.0 (N2) #10-32 (N3)	1/4-20 (N1) M6x1.0 (N2) #10-32 (N3)	1/4-20 (N1) M6x1.0 (N2) #10-32 (N3)	5/16-18 (N1) M8x1.25 (N2) 1/4-28 (N3)	5/16-18 (N1) M8x1.25 (N2) 1/4-28 (N3)	5/16-18 (N1) M8x1.25 (N2) 1/4-28 (N3)	
Threadless	N	N	N	N	N	N	
Rotated Port Configurations <i>(See chart, p. 132)</i>							

Part Numbering Schematic

SS - □ □ □ - □ -
Base Part No.

□ - □
Stroke Options

ALL STAINLESS

3/4", 1-1/16", 1-1/2" & 2" BORE CYLINDERS

BORE SIZE

1-1/2"

2"

Base Part No.	SS-SDR-24-	SS-CDR-24-	SS-SDD-24-	SS-EDR-24-	SS-SDR-32-	SS-UDR-32-	SS-SDD-32-
Cylinder Type	Double-Acting				Double-Acting		
Mounting Style	Stud	Clevis	Stud	End Stud	Stud	Universal	Stud
Rod Type	Rotating	•	•	Double End	•	•	Double End
	Non-Rotating						
Maximum Stroke	12"	32"	19"	39"	12"	32"	12"
Rod Threads	7/16-20				1/2-20		
Options							
Cushions (C, F, R)							
Magnetic Piston (M)	M	M	M	M	M	M	M
Bumpers (B)							
Wipers (W)							
FKM Seals (V)	V	V	V	V	V	V	V
PTFE Grease (TG)	TG	TG	TG	TG	TG	TG	TG
Other Rod Threads (N1, N2, N3)	7/16-14 (N1) M10x1.5 (N2) 3/8-24 (N3)	7/16-14 (N1) M10x1.5 (N2) 3/8-24 (N3)	7/16-14 (N1) M10x1.5 (N2) 3/8-24 (N3)	7/16-14 (N1) M10x1.5 (N2) 3/8-24 (N3)	1/2-13 (N1) M12x1.5 (N2) 7/16-20 (N3)	1/2-13 (N1) M12x1.5 (N2) 7/16-20 (N3)	1/2-13 (N1) M12x1.5 (N2) 7/16-20 (N3)
Threadless	N	N	N	N	N	N	N
Rotated Port Configurations <i>(See chart, p. 132)</i>							

Part Numbering Schematic

SS - □ □ □ - □ -
Base Part No.

□ - □
Stroke Options

Corrosion-Resistant

This line of corrosion-resistant cylinders provides the same advantages of Clippard's superior quality stainless steel cylinders along with the added benefit of corrosion resistance. Featuring acetal heads with double positive seals, these cylinders are designed for harsh environments requiring frequent use of hot water and chemicals. They are ideal for applications where equipment cleanliness is critical.

- Acetal heads with positive double seals
- Designed for harsh environments requiring frequent use of hot water and chemicals
- High quality, precision rolled construction
- Low maintenance, durable design
- Bore sizes from 5/8" up to 1-1/2"
- Magnetic pistons available
- Ideal for applications where equipment cleanliness is critical
- Aluminum alloy pistons (acetal available)

Bore Size	5/8" up to 1 1/2"
Cylinder Type	Double-Acting
Material, End Caps	Acetal
Material, Rod	303 Stainless steel
Material, Seal	Nitrile standard (FKM available)
Material, Tube	304 Stainless steel
Mounting Style	Stud or universal
Pressure, Max.	150 psig
Rod Type	Rotating or double end
Temperature	32 to 180°F
More Info	clippard.com/link/cyl-cr

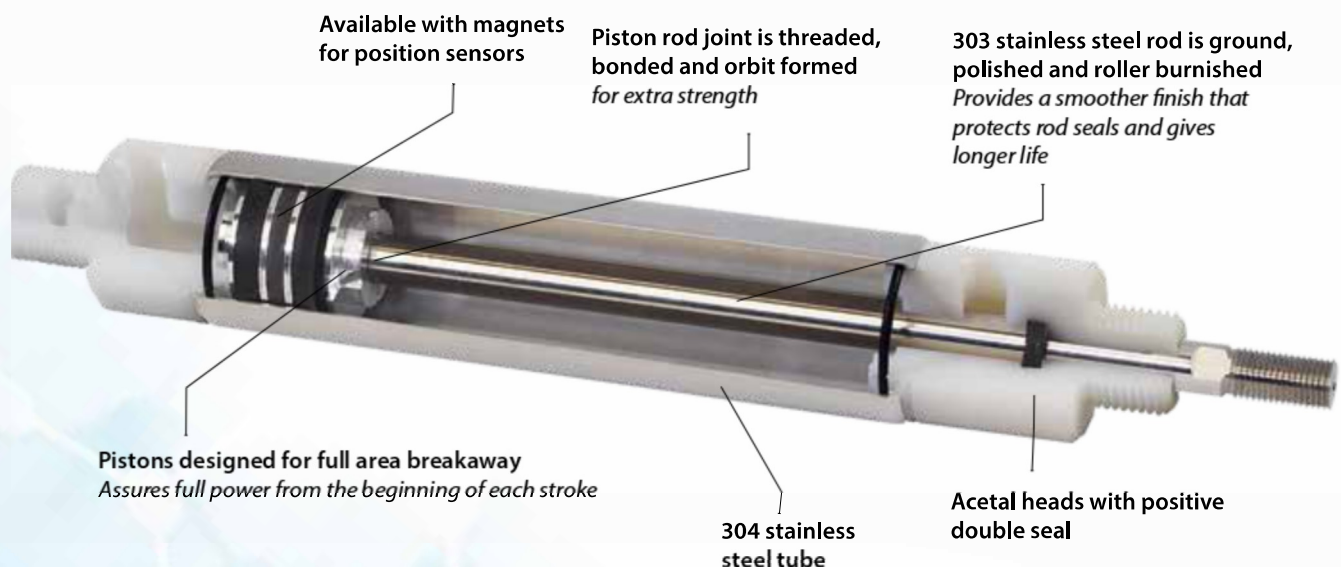

Mounting Options

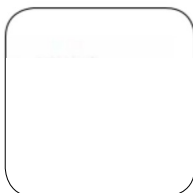

Stud, Front (S)



Universal (U)

ORDERING INFORMATION

Please Note: Not all possible configurations shown below are available. Please reference the charts on the preceding pages for complete details or visit clippard.com/link/cyl-cr to use our online configurator.

After selecting a cylinder from one of the charts, simply add your **stroke** and **options** to the end of the **base part number** listed in the chart. This will provide the complete part number for your cylinder.

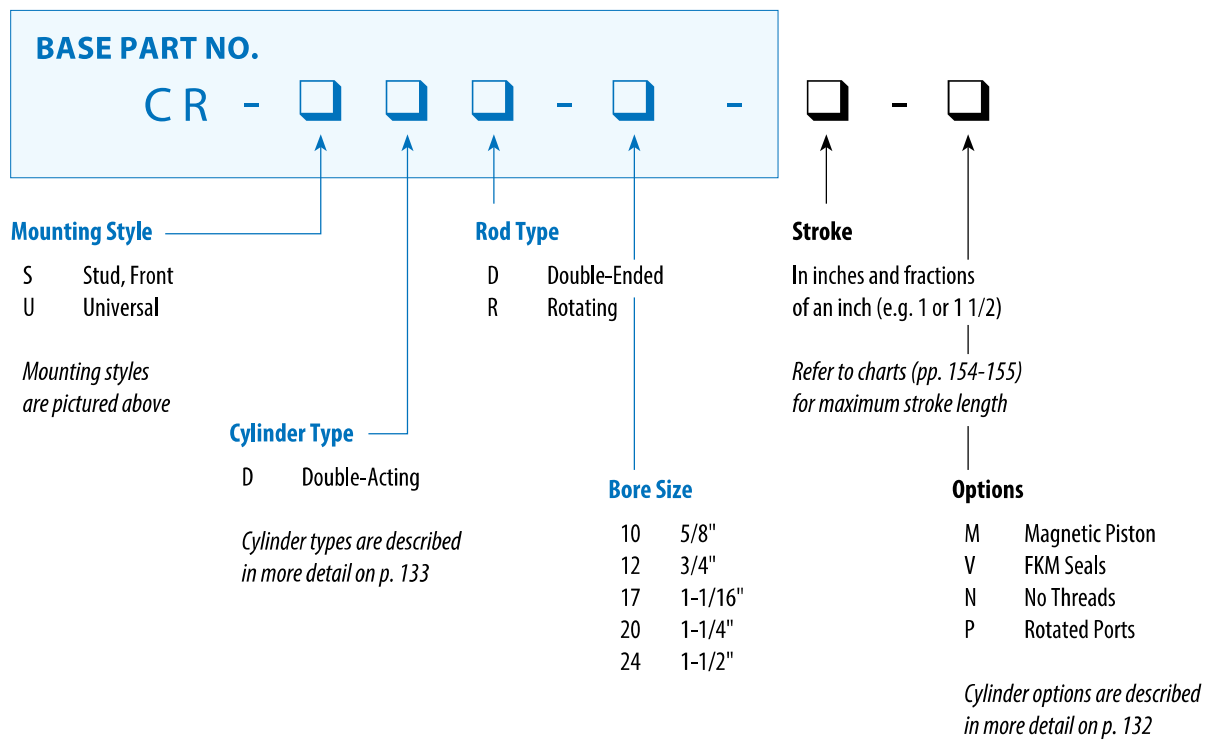

CORROSION-RESISTANT

5/8", 3/4" & 1-1/16" BORE CYLINDERS

BORE SIZE

5/8"

3/4"

1-1/16"

Base Part No.		CR-SDD-10-	CR-SDR-10-	CR-UDR-10-	CR-SDD-12-	CR-SDR-12-	CR-UDR-12-	CR-SDD-17-	CR-SDR-17-	CR-UDR-17-
Cylinder Type		Double-Acting			Double-Acting			Double-Acting		
Mounting Style		Stud	Stud	Universal	Stud	Stud	Universal	Stud	Stud	Universal
Rod Type	Rotating	Double End	•	•	Double End	•	•	Double End	•	•
	Non-Rotating									
Maximum Stroke		20"	43"	43"	20"	42"	41"	20"	42"	41"
Standard Rod Threads		#10-32			1/4-28			5/16-24		
Options	Cushions (C, F, R)									
	Magnetic Piston	M	M	M	M	M	M	M	M	M
	Bumpers									
	Wipers									
	FKM Seals	V	V	V	V	V	V	V	V	V
	PTFE Grease									
	Other Rod Threads (N1, N2, N3)	#10-24 (N1) M5x0.8 (N2) #8-32 (N3)	#10-24 (N1) M5x0.8 (N2) #8-32 (N3)	#10-24 (N1) M5x0.8 (N2) #8-32 (N3)	1/4-20 (N1) M6x1.0 (N2) #10-32 (N3)	1/4-20 (N1) M6x1.0 (N2) #10-32 (N3)	1/4-20 (N1) M6x1.0 (N2) #10-32 (N3)	5/16-18 (N1) M8x1.25 (N2) 1/4-28 (N3)	5/16-18 (N1) M8x1.25 (N2) 1/4-28 (N3)	5/16-18 (N1) M8x1.25 (N2) 1/4-28 (N3)
	Threadless	N	N	N	N	N	N	N	N	N
Rotated Port Configurations (See chart, p. 132)		P2, 3, 4, 5, 6, 7, 8		P2, 3, 4, 5, 6, 7, 8	P2, 3, 4, 5, 6, 7, 8	P6, 7, 8	P2, 3, 4, 5, 6, 7, 8	P6, 7, 8		P2, 3, 4, 5, 6, 7, 8

Part Numbering Schematic

CR-□□□-□□-
Base Part No.

□ - □
Stroke Options

CORROSION-RESISTANT

1-1/4" & 1-1/2" BORE CYLINDERS

BORE SIZE

1-1/4"

1-1/2"

Base Part No.	CR-SDD-20-	CR-SDR-20-	CR-UDR-20-	CR-SDD-24-	CR-SDR-24-	CR-UDR-24-
Cylinder Type	Double-Acting			Double-Acting		
Mounting Style	Stud	Stud	Universal	Stud	Stud	Universal
Rod Type	Rotating	Double End	•	•	Double End	•
	Non-Rotating					
Maximum Stroke	19"	41"	40"	19"	14"	
Standard Rod Threads	3/8-24			7/16-20		
Options						
Cushions (C, F, R)						
Magnetic Piston (M)	M	M	M	M	M	M
Bumpers (B)						
Wipers (W)						
FKM Seals (V)	V	V	V	V	V	V
PTFE Grease (TG)						
Other Rod Threads (N1, N2, N3)	3/8-16 (N1) M8x1.25 (N2) 5/16-24 (N3)	3/8-16 (N1) M8x1.25 (N2) 5/16-24 (N3)	3/8-16 (N1) M8x1.25 (N2) 5/16-24 (N3)	7/16-14 (N1) M10x1.5 (N2) 3/8-24 (N3)	7/16-14 (N1) M10x1.5 (N2) 3/8-24 (N3)	7/16-14 (N1) M10x1.5 (N2) 3/8-24 (N3)
Threadless (N)	N	N	N	N	N	N
Rotated Port Configurations <i>(See chart, p. 132)</i>	P6, 7, 8		P2, 3, 4, 5, 6, 7, 8	P6, 7, 8		P2, 3, 4, 5, 6, 7, 8

Part Numbering Schematic

CR-□□□-□□-

Base Part No.



Stroke



Options

Compact Extruded

Clippard's line of extruded body cylinders are compact, lightweight, and reliable. The standard, interchangeable design and large variety of mounting styles, bore sizes, and available options make this one of the most versatile cylinder lines in the world. This versatility, in combination with Clippard's superior service, fast delivery, and easy-to-use online cylinder interchange guide, helps prevent down time by enabling quick drop-in replacements.

- Available in 7 bore sizes
- Superior service and quick delivery
- Choose from metric or imperial ports
- Multiple mounting options
- Optional GMR sensor slides into groove for low profile mounting
- Custom strokes welcomed
- Interchangeable design allows for quick, drop-in replacements

Bore Size	12 mm, 16 mm, 20 mm, 25 mm, 32 mm, 40 mm, and 50 mm
Cylinder Type	Double-Acting; Single-Acting, Spring Return; or Reverse-Acting, Spring Extended
Magnetic Piston	Available
Material, Rod	303 Stainless steel, chrome-plated
Material, Seal	Nitrile
Material, Body	Aluminum, clear anodized
Mounting Style	Threaded or thru holes
Pressure, Max.	14 to 145 psig (10 bar)
Rod Type	Rotating or double end
Rod Wipers/Seals	Polyurethane
Standard Stroke	From 1/8" up to 4" (5 to 100 mm)
Temperature	-4° to 158°F
More Info	clippard.com/link/cyl-extruded

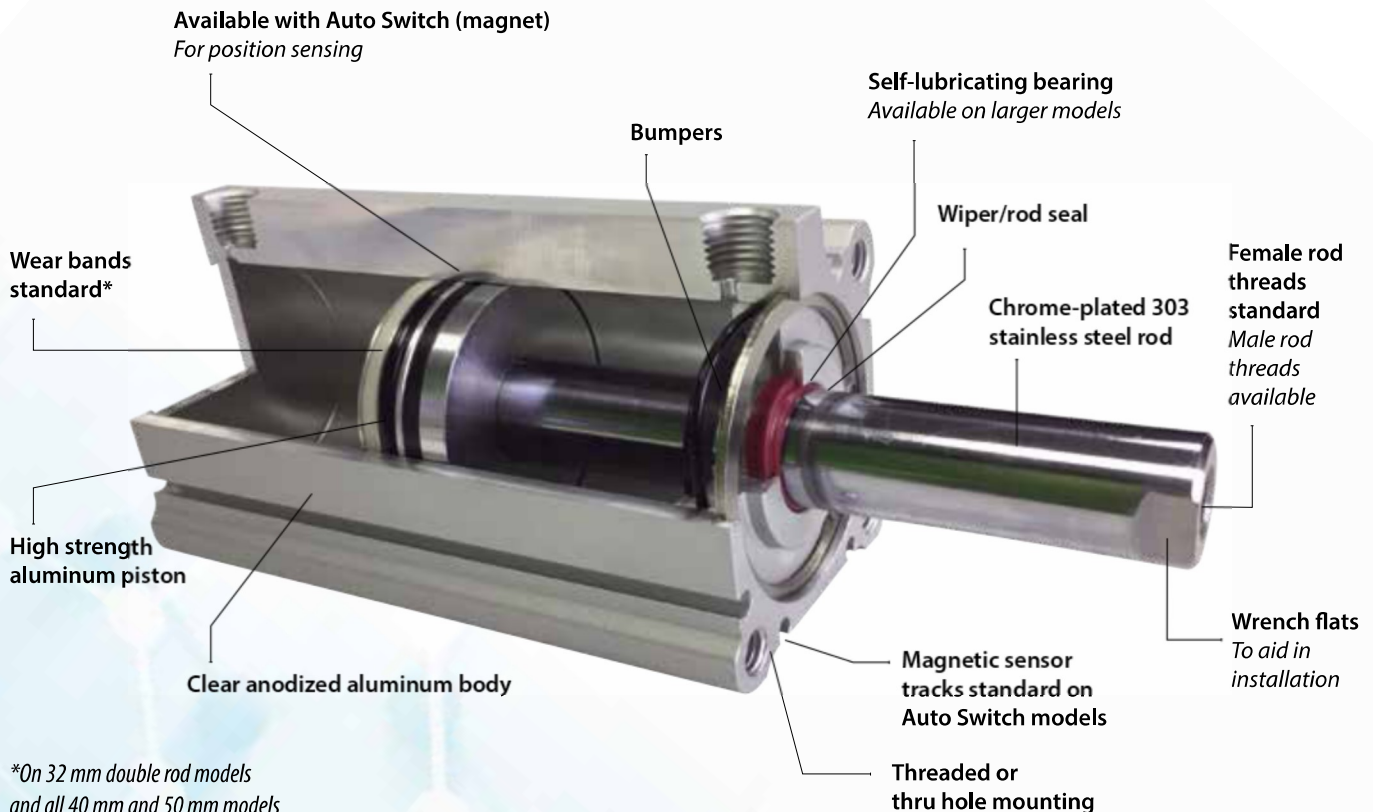

Mounting Options



**Threaded,
Both Ends (A)**



Thru Hole (B)

ORDERING INFORMATION

Please Note: Not all possible configurations shown below are available. Please reference the charts on the preceding pages for complete details or visit clippard.com/link/cyl-extruded to use our online configurator.

After selecting a cylinder from one of the charts, add your **bore size**, **stroke**, and **options** to the end of the **base part number** listed in the chart. This will provide the complete part number for your cylinder.

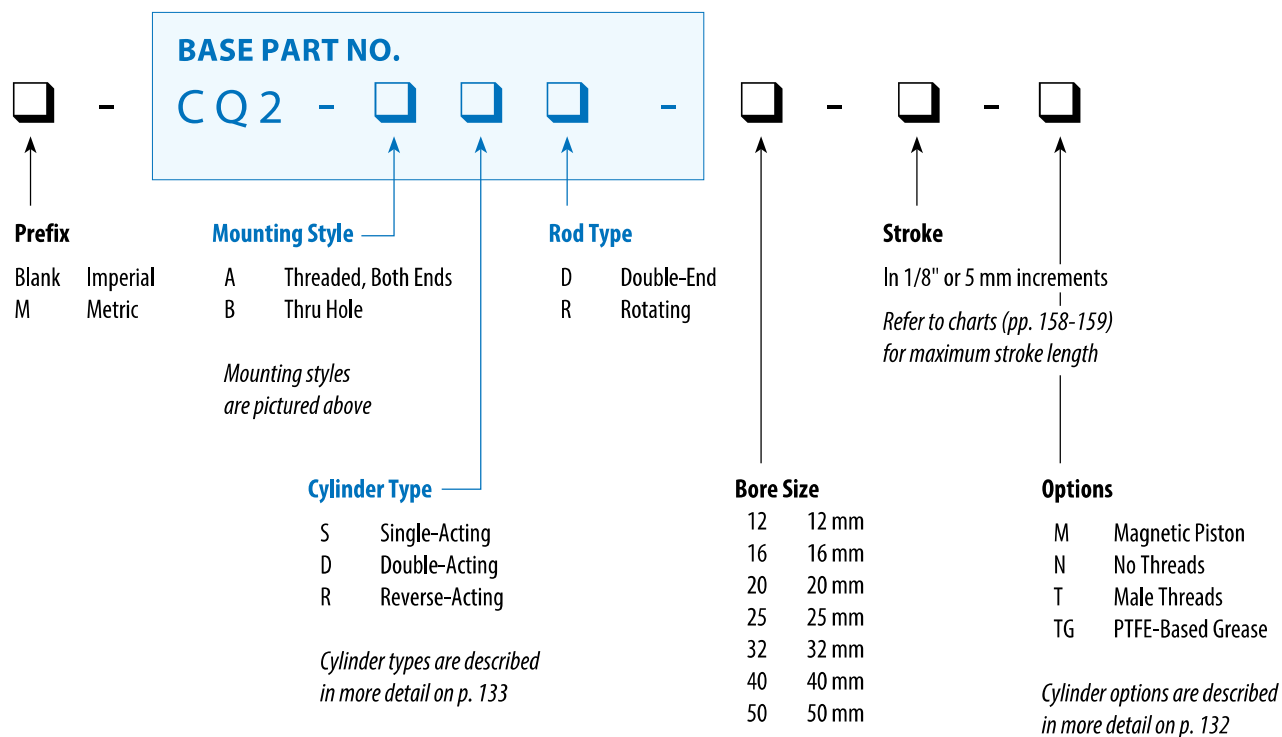

COMPACT EXTRUDED

12, 16, 20 & 25 MM BORE CYLINDERS

BORE SIZE 12 mm & 16 mm

Base Part No.	CQ2-ADR-	CQ2-BDR-	CQ2-ASR-	CQ2-BSR-	CQ2-ARR-	CQ2-BRR-	CQ2-ADD-	CQ2-BDD-
Cylinder Type	Double-Acting		Single-Acting		Reverse-Acting		Double-Acting	
Mounting Style	Threaded	Thru Hole	Threaded	Thru Hole	Threaded	Thru Hole	Threaded	Thru Hole
Rod Type	Rotating	•	•	•	•	•	Double End	Double End
	Non-Rotating							
Maximum Stroke	30 mm (1")	30 mm (1")	20 mm (3/4")	20 mm (3/4")	20 mm (3/4")	20 mm (3/4")	30 mm (1")	30 mm (1")
Options	Magnetic Piston (M)	M	M	M	M	M	M	M
	Threadless (N)	N	N	N	N	N	N	N
	Male Threads (T)	T	T	T	T	T	T	T
	PTFE Grease (TG)	TG	TG	TG	TG	TG	TG	TG

Metric Threads All compact extruded cylinders are also available with **metric threads** (add M- prefix to part number)

Part Numbering Schematic



BORE SIZE 20 mm & 25 mm

Base Part No.	CQ2-ADR-	CQ2-BDR-	CQ2-ASR-	CQ2-BSR-	CQ2-ARR-	CQ2-BRR-	CQ2-ADD-	CQ2-BDD-
Cylinder Type	Double-Acting		Single-Acting		Reverse-Acting		Double-Acting	
Mounting Style	Threaded	Thru Hole	Threaded	Thru Hole	Threaded	Thru Hole	Threaded	Thru Hole
Rod Type	Rotating	•	•	•	•	•	Double End	Double End
	Non-Rotating							
Maximum Stroke	50 mm (2")	50 mm (2")	30 mm (1")	30 mm (1")	30 mm (1")	30 mm (1")	50 mm (2")	50 mm (2")
Options	Magnetic Piston (M)	M	M	M	M	M	M	M
	Threadless (N)	N	N	N	N	N	N	N
	Male Threads (T)	T	T	T	T	T	T	T
	PTFE Grease (TG)	TG	TG	TG	TG	TG	TG	TG

Metric Threads All compact extruded cylinders are also available with **metric threads** (add M- prefix to part number)

Part Numbering Schematic



COMPACT EXTRUDED

32, 40 & 50 MM BORE CYLINDERS

BORE SIZE 32 mm, 40 mm & 50 mm

Base Part No.	CQ2-ADR-	CQ2-BDR-	CQ2-ASR-	CQ2-BSR-	CQ2-ARR-	CQ2-BRR-	CQ2-ADD-	CQ2-BDD-
Cylinder Type	Double-Acting		Single-Acting		Reverse-Acting		Double-Acting	
Mounting Style	Threaded	Thru Hole	Threaded	Thru Hole	Threaded	Thru Hole	Threaded	Thru Hole
Rod Type	Rotating	•	•	•	•	•	Double End	Double End
	Non-Rotating							
Maximum Stroke	100 mm (4")	100 mm (4")	30 mm (1")	30 mm (1")	30 mm (1")	30 mm (1")	100 mm (4")	100 mm (4")
Options	Magnetic Piston (M)	M	M	M	M	M	M	M
	Threadless (N)	N	N	N	N	N	N	N
	Male Threads (T)	T	T	T	T	T	T	T
	PTFE Grease (TG)	TG	TG	TG	TG	TG	TG	TG

Metric Threads All compact extruded cylinders are also available with **metric threads** (add M- prefix to part number)

Part Numbering Schematic



Need to replace a cylinder from another manufacturer? No problem.

- 1 Enter your cylinder part number into any search box on the **clippard.com** website.
- 2 The cylinder will appear in your search results, next to the **Interchange Guide** logo.
- 3 The **Interchange Guide** will display compatible Clippard cylinders.

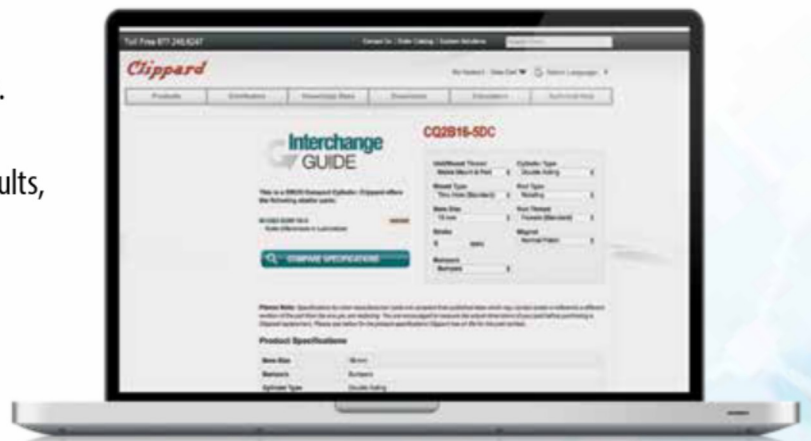

clippard.com/link/interchange

Brass Cylinders

- The **original** miniature pneumatic cylinder
- Rods threaded and bonded to piston
- Nitrile u-cup seals provide smooth, leakproof operation
- Compact, robust design



Bore Size	5/32", 1/4", 3/8", 9/16", 7/8"
Cylinder Type	Single-Acting, Double-Acting
Material, End Caps	Brass and stainless steel
Material, Rod	Stainless steel or brass
Material, Seal	Nitrile
Material, Tube	Brass and stainless steel
Mounting Style	Body, stud, clevis, universal, or body
Pressure, Max.	Varies up to 250 psig
Rod Type	Double end, rotating, non-rotating
Standard Strokes	1/4" up to 6"
Temperature	30 to 180°F
More Info	clippard.com/link/cyl-brass



Mounting Options



Body (P)



Universal (U)



Clevis (C)



Stud (S)

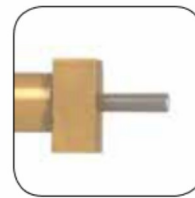

Block (B)

ORDERING INFORMATION

BASE PART NO.

Consult charts (pp. 161-162)

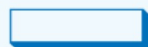

Example Part Number: **MMF-4Z-DM**



Options

N Threadless
T Male Threads

Stroke

In inches and fractions
of an inch

Mounting Options	Cylinder Type	Rod Type	Bore Size
P Body	Single-Acting	D Double-Ended	5/32"
U Universal	Double-Acting	N Non-Rotating	1/4"
C Clevis	Reverse-Acting	R Rotating	3/8"
S Stud			9/16"
B Block			7/8"

BRASS

5/32", 1/4", 3/8" & 9/16" BORE CYLINDERS

BORE SIZE

5/32" 1/4" 3/8"

*Stainless steel

Base Part No.		SM-2*	SM-3*	SM-6	3SS-AR-	3PS-	3SS-	3CS-	3BDS-	3BDD-	3SD-	3CD-
Cylinder Type		Single-Acting		Single-Acting	Reverse-Acting	Single-Acting			Double-Acting			
Mounting Style		Stud	Stud	Body	Stud	Body	Stud	Clevis	Block		Stud	Clevis
Rod Type	Rotating	•	•	•	•		•	•	•	Double End	•	•
	Non-Rotating					•						
Available Stroke Lengths	1/4"	•	•									
	3/8"			•								
	1/2"		•		•	•	•	•				
	3/4"		•									
	1"		•				•	•	•	•	•	•
	2"						•	•	•	•	•	•
	3"						•	•	•	•	•	•
	4"								•	•	•	•
5"								•				
6"								•				
Options	Threadless (N)				N							
	Male Threads (T)						T	T	T	T	T	T

Part Numbering Schematic



-



-



BORE SIZE

9/16" (Continued on next page)

Base Part No.		9PS-	9BS-	9SS-	9CS-	9BDS-	9BDD-	9SD-	9CD-
Cylinder Type		Single-Acting				Double-Acting			
Mounting Style		Body	Block	Stud	Clevis	Block		Stud	Clevis
Rod Type	Rotating		•	•	•	•	Double End	•	•
	Non-Rotating	•							
Available Stroke Lengths	3/4"	•	•	Non-Rotating	•				
	1"					•	•	•	•
	1-1/2"		•	•	•				
	2"		2-1/4"	2-1/4"	2-1/4"	•	•	•	•
	3"		•	•	•	•	•	•	•
	4"					•	•	•	•
	5"					•	•	•	•
	6"					•	•	•	•
9"									
Options	Threadless (N)	N							
	Male Threads (T)		T	T	T	T	T	T	T

CYLINDERS

BRASS

9/16" & 7/8" BORE CYLINDERS

BORE SIZE

9/16" (Continued from previous page)

Base Part No.		95S-AR-	H9S-□S	H9S-□D	H9C-□S	H9C-□D	H9U-□S	H9U-□D	H9D-□D
Cylinder Type		Reverse-Acting	Single-Acting	Double-Acting	Single-Acting	Double-Acting	Single-Acting	Double-Acting	
Mounting Style		Stud			Clevis		Universal		Stud
Rod Type	Rotating	•	•	•	•	•	•	•	Double End
	Non-Rotating								
Available Stroke Lengths	3/4"								
	1"	•	•	•	•	•	•	•	•
	1-1/2"								
	2"		•	•	•	•	•	•	•
	3"		•	•	•	•	•	•	•
	4"			•	•	•	•	•	•
	5"			•	•	•	•	•	•
	6"			•	•	•	•	•	•
9"									
Options	Threadless (N)	N	N	N	N	N	N	N	N
	Male Threads (T)								

Part Numbering Schematic



Base Part No.

-



Stroke

-



Options

BORE SIZE

7/8"

Base Part No.		75S-AR-	75S-	75D-	75-	7D-	7DD-
Cylinder Type		Reverse-Acting	Single-Acting	Double-Acting	Single-Acting	Double-Acting	Double-Acting
Mounting Style		Stud			Universal		Stud
Rod Type	Rotating	•	•	•	•	•	Double End
	Non-Rotating						
Available Stroke Lengths	3/4"						
	1"	•	•	•	•	•	•
	1-1/2"						
	2"			•		•	•
	3"			•		•	•
	4"						
	5"			•		•	•
	6"						
	7"			•		•	•
9"			•		•	•	
Options	Threadless (N)	N	N	N	N	N	N

Air Volume Tanks



Air volume tanks are available in standard stainless steel, all stainless steel, or polypropylene. Each air volume tank includes a threaded port at both ends. See the charts below for tank volumes and ports.

Clippard stainless steel air volume tanks are manufactured using the same high quality, precision rolled construction as Clippard's superior stainless steel cylinders. For additional corrosion resistance, air volume tanks with acetal heads are also available.

- Volumes from 1 to 35 in.³
- 11 models
- Easy to connect, mount, and use in circuits



STAINLESS STEEL

Max. Pressure	250 psig
Material, Tubes	304 Stainless steel
Material, Heads	Aluminum
Options	Anodizing available

Part No.	Volume	Ports
AVT-12-1	1 in. ³	1/8-27
AVT-17-2	2 in. ³	1/8-27
AVT-17-3	3 in. ³	1/8-27
AVT-24-4	4 in. ³	1/8-27
AVT-24-6	6 in. ³	1/8-27
AVT-24-8	8 in. ³	1/8-27
AVT-24-10	10 in. ³	1/8-27
AVT-32-12	12 in. ³	1/4-18
AVT-32-14	14 in. ³	1/4-18
AVT-32-16	16 in. ³	1/4-18

ALL STAINLESS STEEL

Max. Pressure	250 psig
Material, Tubes	304 Stainless steel
Material, Heads	304 Stainless steel

Part No.	Volume	Ports
SS-AVT-12-1	1 in. ³	1/8-27
SS-AVT-17-2	2 in. ³	1/8-27
SS-AVT-17-3	3 in. ³	1/8-27
SS-AVT-24-4	4 in. ³	1/8-27
SS-AVT-24-6	6 in. ³	1/8-27
SS-AVT-24-8	8 in. ³	1/8-27
SS-AVT-24-10	10 in. ³	1/8-27
SS-AVT-32-12	12 in. ³	1/4-18
SS-AVT-32-14	14 in. ³	1/4-18
SS-AVT-32-16	16 in. ³	1/4-18

POLYPROPYLENE

Max. Pressure	125 psig
Material, Tubes	Polypropylene
Material, Heads	Polypropylene
Temp. Range	35 to 100°F
Mounting Clip	AVT-PP-CL

Part No.	Volume	Ports
AVT-PP-35	35 in. ³	1/4" PQ

PROUD SUPPORTER OF



Accessories

STAINLESS STEEL

BORE SIZE	Clevis Bracket Part No.	Foot Bracket Part No.	Rod End Part No.	Rod Clevis Part No.	Stud Nut Part No. (Thd.)	Rod Nut Part No. (Thd.)
5/16"	CB-0595	FB-0891 FB-0592	RE-0585	RC-0581	N04-28A (1/4-28) N04-28B (1/4-28) N06-24A (3/8-24) N06-24B (3/8-24)	N02-40 (5-40)
1/2"	CB-0895	FB-0891 FB-0892	RE-0885	RC-0881	N06-24A (3/8-24) N06-24B (3/8-24) N07-20 (7/16-20)	N03-32 (#10-32)
9/16"	CB-0895	FB-0892	RE-0885	RC-0881	N07-20 (7/16-20)	N03-32 (#10-32)
5/8"	CB-0895	FB-0891 FB-0892	RE-0885	RC-0881	N06-24A (3/8-24) N06-24B (3/8-24) N07-20 (7/16-20)	N03-32 (#10-32)
3/4"	CB-1795	FB-1291 FB-1791	RE-1285	RC-1281	N08-20 (1/2-20) N10-18 (5/8-18)	N04-28A (1/4-28) N04-28B (1/4-28)
7/8"	CB-1795	FB-1791	RE-1285	RC-1281	N10-18 (5/8-18)	N04-28A (1/4-28) N04-28B (1/4-28)
1-1/16"	CB-1795	FB-1791	RE-1785	RC-1781	N10-18 (5/8-18)	N05-24 (5/16-24)
1-1/4"	CB-2095	FB-2491	RE-2085	RC-2081	N12-16 (3/4-16)	N06-24A (3/8-24) N06-24B (3/8-24)
1-1/2"	CB-2495	FB-2491	RE-2485	RC-2481	N12-16 (3/4-16)	N07-20 (7/16-20)
1-3/4"	CB-2495	FB-2891	RE-3285	RC-3281	N16-14 (1-14)	N08-20 (1/2-20)
2"	CB-3295	FB-3291	RE-3285	RC-3281	N20-12 (1 1/4-12)	N08-20 (1/2-20)
2-1/2"	CB-3295	FB-4091	RE-3285	RC-3281	N22-12 (3/8-12)	N08-20 (1/2-20)
3"	CB-4895	FB-4891	RE-4885	RC-4881	N24-12 (1 1/2-12)	N10-18 (5/8-18)

ALL STAINLESS STEEL

BORE SIZE	Clevis Bracket Part No.	Foot Bracket Part No.	Rod End Part No.	Rod Clevis Part No.	Stud Nut Part No. (Thd.)	Rod Nut Part No. (Thd.)
3/4"	CB-1795-SS	FB-1791-SS	RE-1285	RC-1281-SS	N10-18-SS (5/8-18)	N04-28A-SS (1/4-28)
1-1/16"	CB-1795-SS	FB-1791-SS	RE-1785	RC-1781-SS	N10-18-SS (5/8-18)	N05-24-SS (5/16-24)
1-1/2"	CB-2495-SS	FB-2491-SS	RE-2485	RC-2481-SS	N12-16-SS (3/4-16)	N07-20-SS (7/16-20)
2"	CB-3295-SS	FB-3291-SS	RE-3285	RC-3281-SS	N20-12-SS (1 1/4-12)	N08-20-SS (1/2-20)

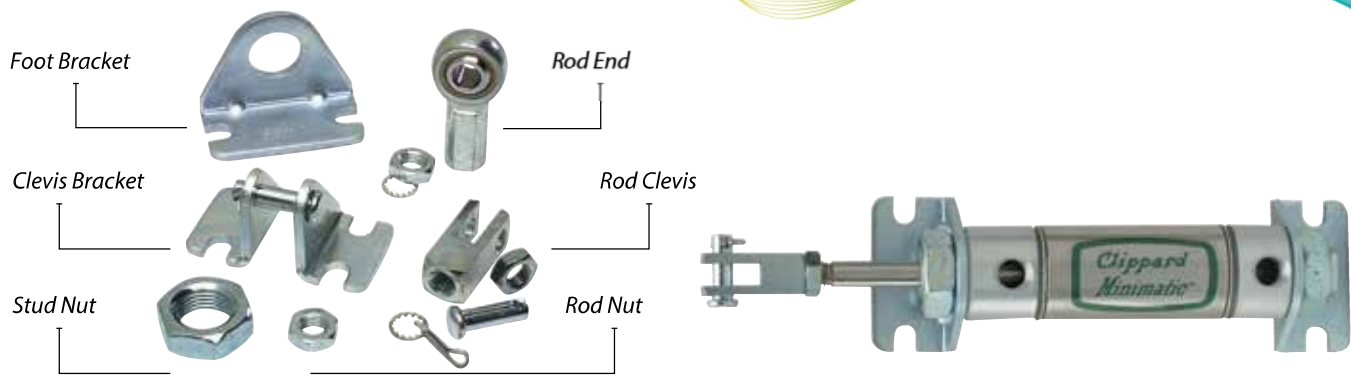

CORROSION-RESISTANT

BORE SIZE	Clevis Bracket Part No.	Foot Bracket Part No.	Rod Clevis Part No.	Stud Nut Part No. (Thd.)	Rod Nut Part No. (Thd.)
5/8"	—	FB-0892-SS	—	N07-20-SS (7/16-20)	—
3/4"	CB-1795-SS	FB-1791-SS	RC-1281-SS	N10-18-SS (5/8-18)	N04-28A-SS (1/4-28)
1-1/16"	CB-1795-SS	FB-1791-SS	RC-1781-SS	N10-18-SS (5/8-18)	N05-24-SS (5/16-24)
1-1/4"	—	FB-2491-SS	—	N16-14-SS (1-14)	—
1-1/2"	CB-2495-SS	FB-2891-SS	RC-2481-SS	N12-16-SS (3/4-16)	N07-20-SS (7/16-20)

BRASS

BORE SIZE	Clevis Bracket Part No.	Flat Bracket Part No.	Angled Bracket Part No.	Foot Bracket Part No.	Rod Clevis Part No.	Ceramic Insulator Part No.
3/8"	—	11917-2	11918-2	—	11996, Male 11997, Female	11767
9/16"	CB-1795	11917-1	11918-1	15018-2	15015 11996, Male 15009, Female	—
7/8"	—	—	—	15018-1	15015	—

COMPACT EXTRUDED

BORE SIZE	Foot Bracket Part No.	Auto Switch Model Foot Bracket Part No.	Rod Nut Part No. (Thd.)
12 mm	CQ2-1292	CQ2-1291	NM5-080 (M5x0.8)
16 mm	CQ2-1692	CQ2-1691	NM6-100 (M6x1.0)
20 mm	CQ2-2092	CQ2-2091	NM8-125 (M8x1.25)
25 mm	CQ2-2592	CQ2-2591	NM10-150 (M10x1.25)
32 mm	CQ2-3292	CQ2-3291	NM14-150 (M14x1.5)
40 mm	CQ2-4092	CQ2-4091	NM14-150 (M14x1.5)
50 mm	CQ2-5092	CQ2-5091	NM18-150 (M18x1.5)

Position Sensors

Clippard stainless steel cylinders that are equipped with a magnetic piston can be used with a **Reed Switch** or **GMR Sensor**. This is an excellent choice for position sensing in pneumatic system control—by accurately sensing the magnetic field of the piston when it passes beneath the sensor, the position of the rod piston is determined, and a feedback signal is created. Some of the benefits of Clippard’s position sensors include: small size, high durability, high sensitivity, high response time, low power consumption and low cost.

To determine which sensor is best suited for your application, refer to the selection chart on the next page.



REED SWITCH

Clippard’s **Reed Switch** is a Single Pole, Single Throw (SPST) Normally-Open electronic switch. When the cylinder’s magnet-equipped piston moves to a location where the magnet is positioned below the Reed Switch, the switch sends a feedback signal to indicate the location of the piston.

A 1/2" minimum stroke is required when multiple sensors are used.

Sourcing Switch with Wire Leads	RPS-P3
Sourcing Switch with Quick-Connect	RPS-P8Q
Sinking Switch with Wire Leads	RPS-N3
Sinking Switch with Quick-Connect	RPS-N8Q
Simple Switch with Wire Leads	RPS-S3
Simple Switch with Quick-Connect	RPS-S8Q

ACCESSORIES

Clippard’s **Universal Mounting Bracket** is designed for use with a Reed Switch or GMR Sensor, on any Clippard Stainless Steel cylinder equipped with a magnetic piston. Hex wrench included.

Universal Mounting Bracket	UC-0848
Mating Cable	CPS-C8Q5

GMR SENSOR

Clippard’s **GMR Sensor** is a solid-state device made up of alternating layers of conductive magnetic and non-magnetic materials. When a magnetic field is applied, there is a large drop in resistance. This decrease produces a signal that can be used to determine the location of the piston.

Sourcing Switch with Wire Leads	GPS-P3
Sourcing Switch with Quick-Connect	GPS-P8Q
Sinking Switch with Wire Leads	GPS-N3
Sinking Switch with Quick-Connect	GPS-N8Q

DIMENSIONS

All RPS- and GPS- Position Sensors

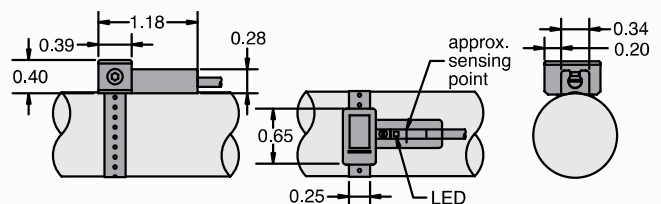

ACCESSORIES

POSITION SENSORS

Part No.	RPS-S3	RPS-S8Q	RPS-N3	RPS-N8Q	RPS-P3	RPS-P8Q	GPS-N3	GPS-N38Q	GPS-P3	GPS-P8Q
Temp. Range	14 to 158°F									
Vibration	9 G									
Enclosure Class.	IP 67 (NEMA 6)									
Connection	3 mm wire leads	8 mm male QC*, 6" pigtail	3 mm wire leads	8 mm male QC*, 6" pigtail	3 mm wire leads	8 mm male QC*, 6" pigtail	3 mm wire leads	8 mm male QC*, 6" pigtail	3 mm wire leads	8 mm male QC*, 6" pigtail
Sensor	Simple switch (2-wire)		NPN current, sinking		PNP current, sourcing		NPN current, sinking		PNP current, sourcing	
Indicator	Red LED		Red LED		Green LED		Red LED		Green LED	
Circuit Diagram										
Oil-Resistant PVC Cable	2.8 S, 2C		2.8 S, 3C		2.8 S, 3C		2.8 S, 3C		2.8 S, 3C	
Max. Switching Freq.	200 Hz		1,000 Hz		1,000 Hz		5,000 Hz		5,000 Hz	
Operating Voltage	5 to 120 VAC	5 to 60 VAC/VDC	5 to 30 VDC		5 to 30 VDC		5 to 28 VDC		5 to 28 VDC	
Max. Current	100 mA		250 mA		250 mA		200 mA		200 mA	
Current Consumption	—		10 mA max. @ 24 V (switch active)		10 mA max. @ 24 V (switch active)		7.5 mA max. @ 24 V (switch active)		7.5 mA max. @ 24 V (switch active)	
Max. Voltage Drop	2.5 V @ 40 mA DC		0.5 V @ 550 mA (resistive load)		0.5 V @ 550 mA (resistive load)		0.5 V @ 200 mA (resistive load)		0.5 V @ 200 mA (resistive load)	
Logic	Single Pole, Single Throw, Normally-Open						Solid-State, Normally-Open			
Type	Reed Switch						GMR Sensor			
Max. Rating	10 W						6 W			
Sensitivity	60 G						40 ~ 750 G			
Max. Leakage Current	—						0.01 mA			
Shock	30 G						50 G			
Protection Circuit	—						Power source reverse polarity; surge suppression			

More Info

clippard.com/link/reed-switch

clippard.com/link/gmr-sensor

QUICK-CONNECT WIRING DIAGRAMS

Part No.	2-Wire Quick-Connect	3-Wire Quick-Connect
Wire Diagram	<p>RPS-S8Q</p>	<p>RPS-N8Q, RPS-P8Q, GPS-N8Q, GPS-P8Q</p>