



P R O D U C T O V E R V I E W

Innovative Valve Technology

INNOVATIVE VALVE TECHNOLOGY – MADE IN GERMANY



Quality, Reliability and Safety – are our understanding of customer service

Over 40 years of experience in development, production and worldwide distribution of solenoid and pressure-operated valves makes GSR Ventiltechnik your partner for reliable valve technology and sustainable quality standards.

Beside our standard product range for general applications are our core business fields:

- High pressure applications up to 1200 bar
- Vacuum applications down to -0,9 bar
- High temperature applications up to +450 °C
- Low temperature applications down to -196 °C
- Engineering and manufacturing of valve block solutions

You're looking for innovative valve technology? Please don't hesitate to contact us.

www.ventiltechnik.de

A company of the [INDUS]

GSR is certified acc. to DIN EN ISO 9001 and has various additional certifications for valves and coils, such as ATEX (2014/34/EU), Germanischer Lloyd, EAC and UL.

To keep our high quality standards, every single valve has to pass in a final operation- and leakage-test before dispatch.



- Errors and modifications subject to change!
- Original products may differ from the product photos due to different materials etc., November 2016.
- © GSR Ventiltechnik GmbH & Co. KG, Vlotho

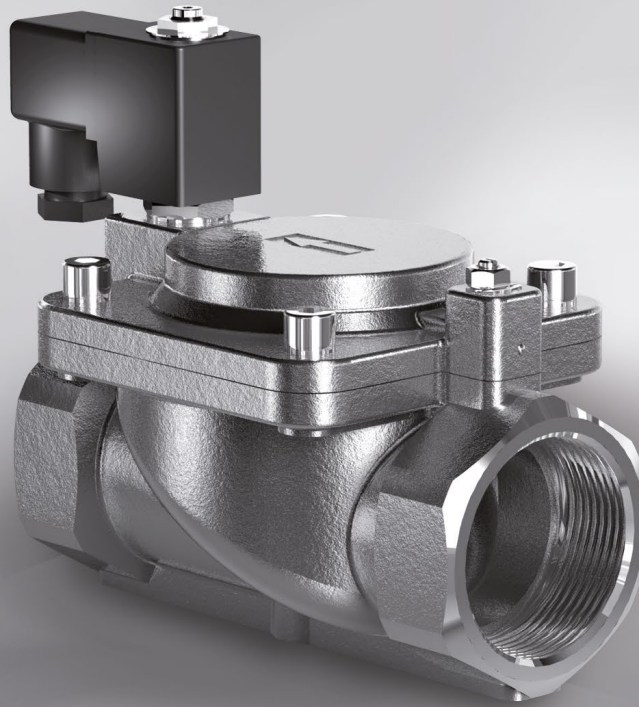

SOLENOID VALVES FOR GENERAL PURPOSES

- Threaded connections: G $\frac{1}{4}$ -G3
- Flanged connections: DN15-DN300
- Further connections: NPT-thread, welding ends, flanges acc. to ANSI and JIS
- Pressure range: 0-40 bar
- Coils with ATEX- or UL-certificate
- Temperature range: -40 °C up to +80 °C
- Body material: Brass, cast iron, cast steel, stainless steel, PA66
- Sealing material: NBR, FKM, EPDM, PTFE

We're manufacturing solenoid valves for liquid and gaseous media in 2/2-way- and 3/2-way-design. Our product range contains

- Pilot operated solenoid valves that are working with a pressure difference between inlet and outlet. These valves are simple and robust in design and are able to handle big dimensions by a comparatively low energy consumption.
- Direct operated solenoid valves which are used in applications for lower pressure ranges. These valves do have just small sized connections but are working without pressure difference to operate the valve.
- Force pilot operated solenoid valves that are working without pressure difference as well but are able to operate big dimensional valves up to 40 bar.

Please note: Detailed technical data sheets are available at
 ↳ www.ventiltechnik.de

Furthermore, we're offering a wide range of valves from our stock or within short delivery time.



type 40



type 28



type 43



type 24



type 52



type 75



type 48FL



type 39



PRESSURE CONTROLLED VALVES FOR GENERAL PURPOSES

- Threaded connections: G $\frac{1}{4}$ -G3
- Flanged connections: DN15-DN250
- Further connections: NPT-thread, welding ends, flanges acc. to ANSI and JIS
- Pressure range: 0-40 bar
- Temperature range: -40 °C up to +200 °C
- Body material: Brass, cast iron, cast steel, spheroidal cast, red brass, stainless steel
- Sealing material: NBR, FKM, EPDM, PTFE
- Available with mechanical ATEX-approval

We're manufacturing pressure operated valves for liquid and gaseous media in 2/2-way- and 3/2-way-design.

Pressure operated valves are working without pressure range and are available for dimensions up to DN250 and are able to handle up to 40 bar operation pressure. The construction of these valves even allows a slight impurity of the medium as well as media viscosities up to 600 cSt, depending on the type of valve.

Our valves are well known in the market for technical reliability and lifetime.

Please note: Detailed technical data sheets are available at
 ↳ www.ventiltechnik.de

Furthermore, we're offering a wide range of valves from our stock or within short delivery time.



type 63 straight seat



type 63



type 63FL



type 22



type 26



type 78



type 79



type 3/151



HIGH PRESSURE VALVES

- Threaded connections: G $\frac{1}{4}$ -G2
- Further connections: NPT-connection, high pressure threads
- Pressure range: 0-1200 bar
- Coils with ATEX- or UL-listing
- Temperature range -40 °C up to +80 °C
- Body material: Brass, stainless steel
- Sealing material: PTFE, PEEK

Applications that require a higher pressure range than 40 bar are covered by our range of high pressure solenoid and pressure operated valves that are available in 2/2-way- and 3/2-way-design for liquid and gaseous media.

Our high pressure valves have proven their long operational lifetime in various applications with our customers.

Please note: Detailed technical data sheets are available at
 ↳ www.ventiltechnik.de

Beside a standard range of high pressure valves that are available ex stock, we're offering also the customized solution for your application.



type 52HD



type 75HD



type 46



type 8/000



type 2/529



type 2/529 pn.



type 8/100



CRYOGENIC VALVES

- Threaded connections: G $\frac{1}{4}$ -G2
- Flanged connections: DN15-DN100
- Further connections: NPT-thread, welding ends, flanges acc. to ANSI and JIS
- Pressure range: 0-40 bar
- Coils with ATEX- or UL-listing
- Temperature range -196 °C up to +60 °C
- Body material: Brass, stainless steel
- Sealing material: PTFE, PEEK

For cryogenic applications down to -196°C, we're offering a range of 2/2-way-design solenoid and pneumatic valves that are used in applications for liquefied, cold gases. Solenoid valves can be equipped with ATEX-certified coils to cover the range of potentially explosive conditions in so appointed areas.

Please note: Detailed technical data sheets are available at
↳ www.ventiltechnik.de

An additional range of valves is covering low temperatures down to -60 °C.



type K35



type K37



type 1/041K



type 90

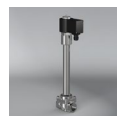

type 91



type 46TK



HIGH TEMPERATURE VALVES

- Threaded connections: G $\frac{1}{4}$ -G2
- Flanged connections: DN15-DN200
- Further connections: NPT-thread, welding ends, flanges acc. to ANSI and JIS
- Pressure range: 0-40 bar
- Temperature range -40 °C up to +450 °C
- Body material: Brass, cast iron, cast steel, spheroidal cast, red brass, stainless steel
- Sealing material: FKM, EPDM, PTFE, PEEK

Our product range for high temperature applications up to +450 °C includes solenoid valves as well as pressure operated valves in 2/2-way design, available in threaded or flanged connection. Those are either equipped with a resilient sealing or a metal sealing, depending on the maximum temperature.

Please note: Detailed technical data sheets are available at
 ↳ www.ventiltechnik.de

Beside a standard range of high temperature valves that are available ex stock, we're offering also the customized solution for your application.



type 51TH



type 37TH



type 35DT



type 37DT



type 2/164DT



type 63DT



type 2/640DT

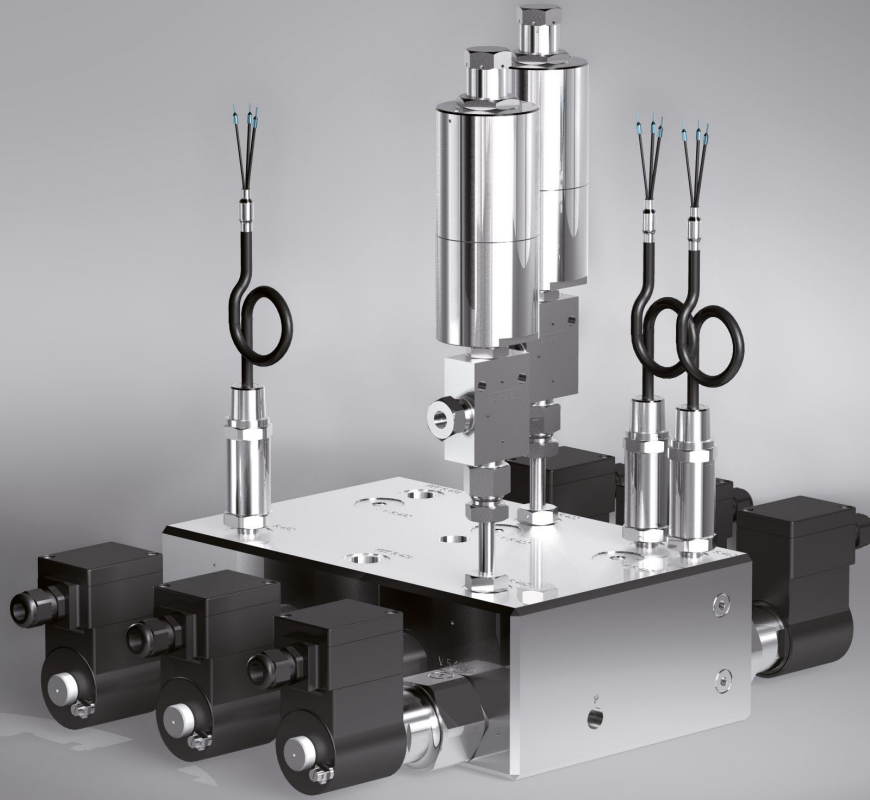

VALVE BLOCK SOLUTIONS

We're offering

- Engineering and development of a solution for your application
- Production and testing according to customer specification
- Detailed technical documentation and advise

Our in-house located R&D department and a production facility that handles the high quantity product series as well as a single piece manufacturing, gives us the opportunity to set up customized solutions on short notice and high quality standard.

Our qualified Team will support you in choosing the type of valve that fits your application.



Low pressure water dispenser



High pressure water dispenser



type 52FL direct operating with flange-top



6-fold high pressure valve block – direct operating



Cartridge pilot operated



6-fold valve block with integrated system components

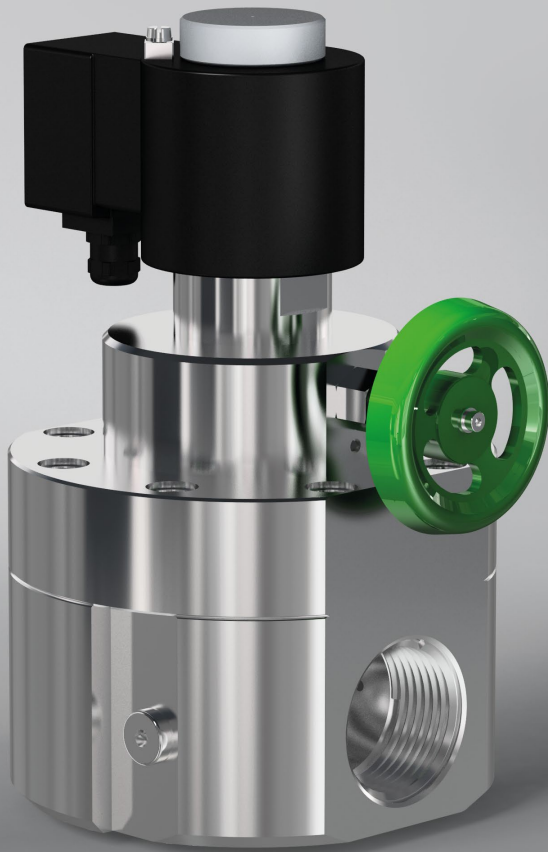

CUSTOMIZED SOLUTIONS

Together with our customers we already developed solutions for

- Washing technology
- High pressure applications
- High temperature applications
- CNG fueling stations
- Shipbuilding

Since the company has been founded in 1971, we developed more than 3000 different types of valves and over 900 additional valve options.

This experience is the foundation for the upcoming innovations in the future.

Our qualified Team will support you in choosing the type of valve that fits your application.



High pressure valve with manual override



High pressure valve with position indicator



High pressure valve with two position indicators and manual override



Extended temperature valve with two position indicators acc. to ATEX



High temperature valve, slow opening on high medium velocity



Normally open with manual override and position indicator



GSR Ventiltechnik GmbH & Co. KG

Im Meisenfeld 1 • D-32602 Vlotho
P.O. Box 1679 • D-32590 Vlotho

☎ +49 5228 779-0
☎ +49 5228 779-190

info@ventiltechnik.de
www.ventiltechnik.de